

yakin

JAWAPAN

FIZIK

KERTAS 1 / Paper 1

- 1 B Pertukaran unit km h^{-1} kepada m s^{-1}
Converting the unit of km h^{-1} to m s^{-1}

$$\frac{35 \times 1\,000}{60 \times 60} = 9.7 \text{ m s}^{-1}$$

- 2 A I ialah termometer yang digunakan untuk mengukur suhu
is a thermometer used to measure temperature
II ialah pita pengukur yang digunakan untuk kuantiti asas untuk panjang
is measuring tape that are used for measure base quantities for length

- 3 D $Ft = mv - mu$
= jisim \times halaju/mass \times velocity
= kg m s^{-1}

$$Ns = \text{kg m s}^{-2} \times \text{s}$$
$$= \text{kg m s}^{-1}$$

- 4 A Lima titik yang pertama sama jarak menunjukkan gerakan halaju seragam dan seterusnya mengalami nyahpecutan kerana jarak antara titik semakin berkurang
The first five points show uniform velocity motion and then decelerate as the distance between the points decreases

- 5 D Halaju motosikal semakin bertambah. Motosikal memecut secara seragam pada arah bertentangan iaitu ke kiri.
The speed of the motorcycle is increasing. A motorcycle accelerates uniformly in the opposite direction, i.e. to the left.

- 6 D Jisim besar, inersia besar
Bigger mass, bigger inertia

- 7 B Pecutan objek yang jatuh bebas disebabkan oleh daya tarikan graviti dinamakan pecutan graviti, g
The acceleration of a free falling object caused by gravitational force is known as gravitational acceleration, g

- 8 C Data yang diperlukan untuk menghitung jisim bumi
Data that are needed to calculate the mass of the earth

II Jejari orbit mana-mana satelit atau bulan
Radius of the orbit any satellite or the moon

III Tempoh pendedaran jasad
Period of revolution of the body

- 9 B $v = \sqrt{\frac{GM}{R+h}}$
 $= \sqrt{\frac{6.67 \times 10^{-11} \times 5.97 \times 10^{24}}{6.37 \times 10^6 + 20.2 \times 10^6}}$
 $= 3.87 \times 10^3 \text{ m s}^{-1}$

- 10 D Tempoh orbitnya ialah 24 jam, iaitu sama dengan tempoh putaran Bumi
Its orbital period is 24 hours, that is the same as the period of rotation of the Earth

- 11 D Muatan haba yang rendah akan cepat panas dan sejuk
Lower specific heat capacity became hot and cool faster

- 12 C Haba yang dihilangkan oleh air panas = haba yang diperoleh oleh air sejuk
Heat lost by hot water = heat gained by cold water
- 13 D $c = \frac{36\,000}{0.6 \times 30}$
 $= 2\,000 \text{ J kg}^{-1} \text{ }^\circ\text{C}^{-1}$
- 14 B Pelembapan ialah pengurangan amplitud suatu ayunan akibat kehilangan tenaga
Damping is the reduction in amplitude in an oscillating system due to loss of energy
- 15 B Pembiasan gelombang berlaku apabila menghampiri pantai kerana perbezaan kedalaman, maka halaju dan panjang gelombang berubah tetapi frekuensi malar
Wave refraction occurs when approaching the shore due to the difference in depth, so the velocity and wavelength change but the frequency is constant
- 16 C Pembelauan gelombang ialah penyebaran gelombang apabila gelombang itu merambat melalui suatu celah atau tepi suatu penghalang
Diffraction of waves is the spreading of waves when the waves propagate through a gap or the edge of a barrier
- 17 B $\lambda = \frac{ax}{D}$
 $x = \frac{6.4 \times 10^{-7} \times 3}{0.4 \times 10^{-3}}$
 $= 4.8 \times 10^{-3}$
- 18 C $\frac{1}{u} + \frac{1}{v} = \frac{1}{f}$
 $\frac{1}{f} = \frac{1}{10} + \frac{1}{20}$
 $f = 6.67 \text{ cm}$
- 19 B Imej akhir yang terbentuk ialah dibesarkan, songsang dan maya
Final image formed is magnified, inverted and virtual
- 20 B Cermin bintik buta
Blind spot mirror
 Cermin cembung diletakkan di selekoh tajam yang berbahaya untuk meluaskan medan penglihatan
A convex mirror is placed at sharp corners to widen the field of vision of the driver
- 21 A Daya pasukan merah lebih besar dari pasukan biru, maka 150 N bertindak ke arah pasukan Merah
The red team's force is greater than the blue teams, so 150 N acts towards the Red team
- 22 A Dua daya bertindak ke atas satu objek pada arah yang tidak berserenjang antara satu sama lain
Two forces act on an object in direction that are not perpendicular to each other

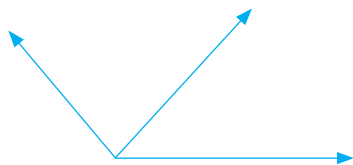

23 D

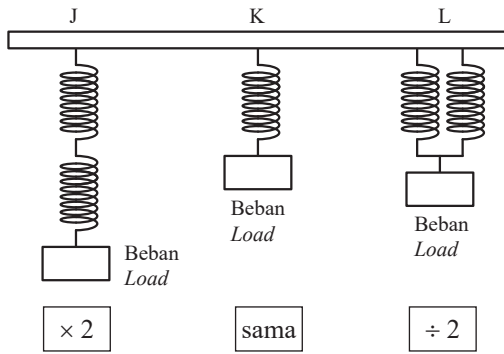

24 A $P = h\rho g$
 dengan keadaan/*where*
 h = kedalaman/*depth*
 ρ = ketumpatan/*density*

25 B Daya apungan
Buoyancy force

26 D Tekanan gas, $P = \text{Tekanan atmosfera} + \text{Tekanan yang dikenakan oleh turus merkuri}$
Gas pressure, $P = \text{Atmospheric pressure} + \text{Pressure exerted by mercury column}$
 $P = 75 + 5$
 $= 80 \text{ cm Hg}$

27 B Kuasa = $\frac{\text{Tenaga elektrik yang digunakan}}{\text{Masa yang diambil}}$
Power = $\frac{\text{Energy used}}{\text{time taken}}$

28 C $E = Pt$
 $= 1.2 \times 20 \times 24$
 $= 576$

100 unit pertama: $100 \times 0.23 = 23$

First 100 units

476 unit kedua : $476 \times 0.25 = 119$

Second 476 units

Kos Keseluruhan/*Total cost* = $23 + 119$
 $= \text{RM}142.00$

29 B $V = IR$
 $= 0.5(3)$
 $= 1.5 \text{ V}$

30 A Petua Genggaman Tangan Kanan
Right Hand Grip Rule

31 C Transformator tidak berfungsi dengan bekalan kuasa arus terus kerana arus terus tidak menghasilkan arus ulang-alik untuk menghasilkan medan magnet yang berubah-ubah dari segi magnitud dan arah
Transformer does not work with a direct current power supply because direct current cannot produce an alternating current for producing a magnetic field that changes in magnitude and direction.

32 A Pancaran termion ialah pemancaran elektron bebas daripada permukaan logam yang dipanaskan
Thermionic emission is the emission of free electrons from a heated metal surface

33 C Mentol menyala kerana sambungan adalah pincang hadapan. Diod jenis-P disambung ke terminal positif dan jenis-N disambungkan kepada terminal negatif bateri.
The bulb lights up because the connection is forward bias. The P-type diode is connected to the negative terminal of a battery.

34 D Jenis npn / npn type

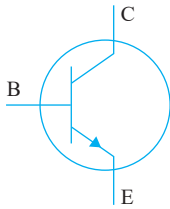

C: Pengumpul
Collector

B: Tapak
Base

E: Pengeluar
Emitter

35 A Nombor nukleon/*Nucleon number* = $210 - 206$
 $= 4$

Nombor proton/*Proton number* = $84 - 82$
 $= 2$

Zarah Alfa/*Alpha particle* = ${}^4_2\text{He}$

36 B $Q = mc^2$
 $= 2.988 \times 10^{-28} \times (3 \times 10^8)^2$
 $= 2.69 \times 10^{-11}\text{J}$

37 B Rod pengawal/*Controls Rod*

- Berfungsi mengawal tindak balas dan menyerap neutron berlebihan
Controls the reaction rate by absorbing excess neutrons
- Dibuat daripada boron dan kadmium
Made of boron or cadmium

38 A Foton ialah tenaga cahaya yang wujud dalam bentuk paket tenaga
Light energy exists in the form of energy packets known as photon

39 C Semakin tinggi keamatan cahaya suatu jasad hitam, semakin banyak tenaga cahaya terpancar daripadanya
The higher the light intensity of a black body, the more light energy it emits

40 D $p = \frac{nhc}{\lambda}$

$$n = \frac{p\lambda}{hc} \quad ; \quad E = \frac{hc}{\lambda}$$

$$= \frac{400}{4.91 \times 10^{-19}}$$

$$= 8.15 \times 10^{20}$$

Bahagian A/Section A

Soalan Questions		Jawapan Answers	Sub markah Subs marks	Jumlah markah Total marks
1	(a)	✓ – kuantiti vektor <i>vector quantity</i>	1	4
	(b)	Sesaran/ <i>Displacement</i>	1	
	(c)	$s = \left[\frac{1}{2} (2 + 4) \times 10 \right] + \left(\frac{1}{2} \times 2 \times 10 \right) - \left(\frac{1}{2} \times 2 \times 10 \right)$ $= 30 \text{ m}$	1 1	
2	(a)	Dua objek bersentuhan secara terma mencapai suhu yang sama, di mana haba bersih yang dipindahkan ialah sifar. <i>Two objects that are in thermal contact achieve the same temperature, where net heat transfer is zero.</i>	1	5
	(b) (i)	$Q = mc\theta$ $= 0.1 \times 4\,200 \times (100 - 55)$ $= 18\,900 \text{ J}$	2	
	(ii)	Suhu berkurang//menurun//lebih rendah <i>Temperature decreases//lower</i>	1	
	(iii)	✓ – sama dengan jumlah haba yang dibebaskan oleh air dididih. <i>equal to the amount of heat released by the boiled water.</i>	1	
3	(a)	Daya semesta/Daya tarikan semula jadi antara mana-mana dua jasad <i>Universal force/Force of attraction between two bodies</i>	1	6
	(b) (i)	Berkadar terus <i>Directly proportional</i>	1	
		(ii) Berkadar songsang <i>Inversely proportional</i>	1	
	(iii)	$\frac{(6.67 \times 10^{-11})(75)(55)}{(2.0)^2}$ $= 6.88 \times 10^{-8} \text{ N}$	2	
(c)	Daya graviti tersebut mempunyai magnitud yang sangat kecil. <i>The gravitational force has a very small magnitude.</i>	1		
4	(a)	Perintang Peka Cahaya (PPC) <i>Light Dependent Resistor (LDR)</i>	1	9
	(b) (i)	$V_{LM} = \frac{40}{40 + 10} \times 6$ $= 4.8 \text{ V}$	2	
		(ii)	$I = \frac{4.8}{40}$ $= 0.12 \text{ mA}$	
(c)	– Rintangan PPC adalah sangat tinggi. <i>The resistance of LDR is very high.</i> – Voltan yang merentasi PPC adalah tinggi. <i>The voltage across LDR is high.</i> – Arus tapak akan mengalir. <i>Base current will flow.</i> – Transistor dihidupkan. <i>Transistor is switched on.</i>	4		

Soalan Questions		Jawapan Answers	Sub markah Subs marks	Jumlah markah Total marks	
5	(a)	Cahaya dengan satu panjang gelombang//satu warna <i>The light which has single wavelength//one colour</i>	1	9	
	(b)	Interferens memusnah menghasilkan pinggir-pinggir gelap. <i>Destructive interference produces dark fringes.</i>	1		
	(c)	– Jarak antara dua pinggir berturutan bagi cahaya merah lebih jauh daripada cahaya biru. <i>The distance between two consecutive bright fringes for red light is further than blue light.</i> – Jarak antara dua pinggir berturutan bagi cahaya yang sama adalah sama. <i>The distance between two consecutive bright fringes for the same light are constant.</i>	2		
	(d)	Apabila panjang gelombang bertambah, jarak di antara pinggir-pinggir terang yang berturutan bertambah. <i>The longer the wavelength, the longer the distance between consecutive bright fringes.</i>	1		
	(e) (i)	Jarak di antara pinggir-pinggir terang berturutan akan berkurang. <i>The distance between consecutive bright fringes will decrease.</i>	1		
	(ii)	Interferens gelombang <i>Interference of waves</i>	1		
	(f)	$x = \frac{1.5 \times 10^{-2} \text{ m}}{3}$ $= 0.005 \text{ m}$ $\lambda = \frac{5.0 \times 10^{-4} \times 0.005}{3.0}$ $= 8.33 \times 10^{-7} \text{ m}$	2		
6	(a)	Alur elektron yang bergerak dengan kelajuan tinggi dalam vakum <i>Beams of electrons moving at high speed in a vacuum</i>	1	9	
	(b)	(i)	Voltan yang dibekalkan dalam Rajah 6(a) kurang daripada Rajah 6(b). <i>The voltage supplied in Diagram 6(a) is less than in Diagram 6(b).</i>		1
		(ii)	Halaju elektron dalam Rajah 6(a) kurang daripada dalam Rajah 6(b). <i>The velocity of electron in Diagram 6(a) is less than in Diagram 6(b).</i>		1
		(iii)	Keamatan tompok hijau dalam Rajah 6(a) kurang daripada dalam Rajah 6(b). <i>The intensity of green dot in Diagram 6(a) is less than in Diagram 6(b).</i>		1
	(c)	(i)	Apabila voltan yang dibekalkan bertambah, halaju elektron bertambah. <i>When the voltage supplied increases, the velocity of electron increases.</i>		1
		(ii)	Apabila halaju elektron bertambah, keamatan tompok hijau bertambah. <i>When the velocity of electron increases, the intensity of green dot increases.</i>		1
	(d)	– Elektron terbebas daripada filamen yang dipanaskan melalui pancaran termion. <i>Electrons are emitted from the hot filament through thermionic emission.</i> – Elektron tertarik ke anod. <i>Electrons are attracted to the anode.</i> – Elektron menghentam skrin pendaflour.//Skrin pancarkan cahaya hijau.//Tenaga kinetik berubah kepada tenaga cahaya. <i>Electrons strike the fluorescent screen.//The screen emits green light.//Kinetic energy changes to light energy.</i>	3		

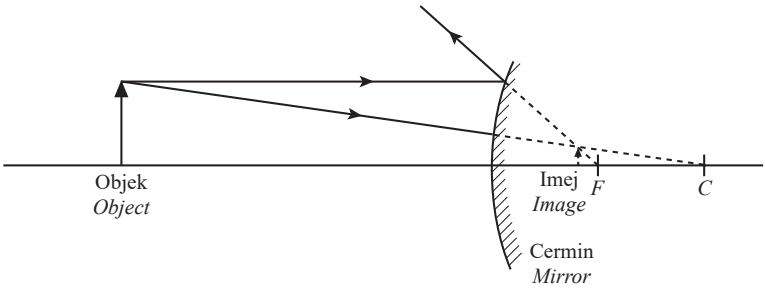
Soalan Questions		Jawapan Answers	Sub markah Subs marks	Jumlah markah Total marks
7	(a)	Medan/Sudut penglihatan lebih luas <i>Wider field/angle of view</i>	1	
	(b) (i)		2	
	(ii)	Diperkecilkan/Tegak/Maya <i>Diminished/Upright/Virtual</i> (Mana-mana dua/Any two)	1	
	(c) (i)	Cembung/ <i>Convex</i> Medan penglihatan lebih luas.//Cahaya boleh dipantulkan pada sudut yang lebih besar ke dalam mata pemerhati. <i>Wider field of view.//Light can be reflected at a larger angle into the observer's eye.</i>	2	
	(ii)	Jejari kelengkungan yang panjang/ <i>Long radius of curvature</i> Diameter lebih besar.//Medan penglihatan lebih luas. <i>Bigger diameter.//Wider field of view.</i>	2	
	(d)	T	1	
8	(a)	Prinsip Archimedes/ <i>Archimedes' principle</i>	1	
	(b)	Daya apungan/ <i>Buoyant force</i> Berat belon udara panas/ <i>Weight of hot air balloon</i>	2	
	(c) (i)	Size belon yang besar/ <i>Big size of balloon</i> Menyesarkan isi padu udara yang besar//Daya apungan yang besar <i>To displace large volume of air//Large buoyant force</i>	2	
	(ii)	Tambah bilangan pembakar/ <i>Add more number of burners</i> Dapat memanaskan udara dengan lebih cepat <i>To heat up the air faster</i>	2	
	(iii)	Jumlah berat belon yang lebih kecil/ <i>Smaller total weight of balloon</i> Menghasilkan daya paduan ke atas yang lebih besar <i>To produce larger upward resultant force</i>	2	

Bahagian B/Section B

Soalan Questions		Jawapan Answers	Sub markah Subs marks	Jumlah markah Total marks
9	(a)	Darjah kepanasan/ <i>Degree of hotness</i>	1	
	(b)	<ul style="list-style-type: none"> – Apabila termometer diletakkan di bawah lidah pesakit, berlakunya sentuhan terma. <i>When a thermometer is placed below the patient's tongue, thermal contact occurs.</i> – Haba dari badan dipindahkan ke bebuli merkuri termometer. <i>Heat from the body is transferred to the mercury bulb of thermometer.</i> 		

Soalan Questions		Jawapan Answers	Sub markah Subs marks	Jumlah markah Total marks															
		<p>– Pengaliran haba berlaku sehingga mencapai keseimbangan terma. <i>Heat flow occurs until thermal equilibrium is achieved.</i></p> <p>– Pengembangan merkuri yang disebabkan oleh penyerapan haba berhenti apabila mencapai keseimbangan terma.//Termometer menunjukkan suhu badan. <i>The expansion of mercury due to heat absorption stops when thermal equilibrium is achieved.//The thermometer shows the body temperature.</i></p>	4																
	(c) (i)	$\theta = \frac{l_{\theta} - l_0}{l_{100} - l_0} \times 100^{\circ}\text{C}$ $= \frac{12 - 5}{25 - 5} \times 100^{\circ}\text{C}$ $= 35^{\circ}\text{C}$	2																
	(ii)	$\theta = 35 + 273$ $= 308 \text{ K}$	2																
	(iii)	Legap//Mempunyai takat didih tinggi//Boleh mengembang secara sekata <i>Opaque//Has high boiling point//Can expand uniformly</i>	1																
	(d)	<table border="1"> <thead> <tr> <th>Aspek Aspect</th> <th>Pilihan Choice</th> <th>Alasan Reason</th> </tr> </thead> <tbody> <tr> <td>Cecair yang digunakan <i>Liquid used</i></td> <td>Merkuri <i>Mercury</i></td> <td>Pengembangan yang sekata/Legap <i>Uniform expansion/Opaque</i></td> </tr> <tr> <td>Dinding bebuli kaca <i>Wall of glass bulb</i></td> <td>Nipis <i>Thin</i></td> <td>Peka dengan perubahan suhu <i>Sensitive to the changes in temperature</i></td> </tr> <tr> <td>Diameter tiub kapilari <i>Diameter of capillary tube</i></td> <td>Kecil <i>Small</i></td> <td>Mudah untuk menunjukkan perubahan suhu <i>Easy to show changes in temperature</i></td> </tr> <tr> <td>Panjang termometer <i>Length of thermometer</i></td> <td>Panjang <i>Long</i></td> <td>Menunjukkan julat bacaan suhu lebih besar <i>Show wider range of temperature readings</i></td> </tr> </tbody> </table> <p>Pilihan/Choice : Y</p>	Aspek Aspect	Pilihan Choice	Alasan Reason	Cecair yang digunakan <i>Liquid used</i>	Merkuri <i>Mercury</i>	Pengembangan yang sekata/Legap <i>Uniform expansion/Opaque</i>	Dinding bebuli kaca <i>Wall of glass bulb</i>	Nipis <i>Thin</i>	Peka dengan perubahan suhu <i>Sensitive to the changes in temperature</i>	Diameter tiub kapilari <i>Diameter of capillary tube</i>	Kecil <i>Small</i>	Mudah untuk menunjukkan perubahan suhu <i>Easy to show changes in temperature</i>	Panjang termometer <i>Length of thermometer</i>	Panjang <i>Long</i>	Menunjukkan julat bacaan suhu lebih besar <i>Show wider range of temperature readings</i>	10	20
Aspek Aspect	Pilihan Choice	Alasan Reason																	
Cecair yang digunakan <i>Liquid used</i>	Merkuri <i>Mercury</i>	Pengembangan yang sekata/Legap <i>Uniform expansion/Opaque</i>																	
Dinding bebuli kaca <i>Wall of glass bulb</i>	Nipis <i>Thin</i>	Peka dengan perubahan suhu <i>Sensitive to the changes in temperature</i>																	
Diameter tiub kapilari <i>Diameter of capillary tube</i>	Kecil <i>Small</i>	Mudah untuk menunjukkan perubahan suhu <i>Easy to show changes in temperature</i>																	
Panjang termometer <i>Length of thermometer</i>	Panjang <i>Long</i>	Menunjukkan julat bacaan suhu lebih besar <i>Show wider range of temperature readings</i>																	
10	(a) (i)	<p>Fenomena di mana suatu permukaan logam disinari oleh alur cahaya yang mempunyai frekuensi tertentu, elektron daripada logam itu dapat dipancar keluar. <i>A phenomenon where a metal surface is illuminated by a beam of light at a certain frequency, electrons can be emitted from the metal.</i></p>	1																
	(ii)	<p>– Semakin tinggi frekuensi foton cahaya, semakin tinggi tenaga kinetik fotoelektron yang dipancarkan daripada permukaan logam. <i>The higher the frequency of the photon of light, the higher the kinetic energy of the photoelectrons emitted from the metal surface.</i></p> <p>– Frekuensi minimum cahaya yang dapat mengeluarkan elektron dikenali sebagai frekuensi ambang, f_0 bagi suatu logam. <i>The minimum frequency of light needed for a metal to emit electrons is known as the threshold frequency, f_0 for the metal.</i></p>																	

Soalan Questions		Jawapan Answers	Sub markah Subs marks	Jumlah markah Total marks
		<p>– Tenaga kinetik fotoelektron tidak bergantung pada keamatan cahaya. Keamatan cahaya yang bertambah tidak menghasilkan fotoelektron yang lebih bertenaga kinetik. <i>The kinetic energy of photoelectrons does not depend on the intensity of light. An increase in the light intensity does not produce photoelectrons with a higher kinetic energy.</i></p> <p>– Fotoelektron dipancar secara serta-merta apabila permukaan logam disinari dengan cahaya. <i>Photoelectrons are emitted instantaneously when a metal surface is irradiated by light.</i></p>	4	
	(b)	$\lambda = \frac{c}{f}$ $= \frac{3.0 \times 10^8}{5.0 \times 10^{14}}$ $= 6.0 \times 10^{-7}$ $= 600 \text{ nm}$ <p>Syarat untuk elektron dipancarkan dari permukaan logam: <i>Conditions for electron to be emitted from a metal surface:</i></p> <p>– Frekuensi sinar gelombang lebih tinggi daripada frekuensi ambang logam. <i>The wave radiation frequency is higher than the threshold frequency of metal.</i></p> <p style="text-align: center;">atau/or</p> <p>– Panjang gelombang kurang daripada panjang gelombang ambang logam. <i>Wavelength is less than the threshold wavelength of the metal.</i></p> <p>Logam/Metal J ($\lambda_0 = 480 \text{ nm}$) Panjang gelombang sinar elektromagnet lebih daripada panjang gelombang ambang logam J, di mana frekuensinya kurang daripada frekuensi ambang logam J. Maka, tiada elektron dibebaskan dari permukaan logam J. <i>Wavelength of the electromagnetic ray is more than threshold wavelength of metal J, where its frequency is less than the threshold frequency of metal J. Hence, no electron is released from surface of metal J.</i></p> <p>Logam/Metal K ($\lambda_0 = 688 \text{ nm}$) Panjang gelombang sinar elektromagnet kurang daripada panjang gelombang ambang logam K, di mana frekuensinya lebih daripada frekuensi ambang logam K. Maka, elektron dibebaskan dari permukaan logam K. <i>Wavelength of the electromagnetic ray is less than threshold wavelength of metal K, where its frequency is more than the threshold frequency of metal K. Hence, electron is released from surface of metal K.</i></p>	5	

Soalan Questions		Jawapan Answers			Sub markah Subs marks	Jumlah markah Total marks
(c)		Ciri-ciri Characteristics	Pilihan Choice	Penerangan Explanation		
	Sumber cahaya <i>Light source</i>	Inframerah <i>Infrared</i>	Kurang merbahaya/Kesan radiasi lebih kecil berbanding dengan ultraungu <i>Less harmful/Smaller radiation effect compared to ultraviolet</i>			
	Keamatan sumber cahaya <i>Light source intensity</i>	Rendah <i>Low</i>	Jimat tenaga <i>Energy saving</i>			
	Jenis sel foto <i>Types of photocell</i>	Semikonduktor <i>Semiconductor</i>	Bersaiz kecil/Penggunaan kuasa yang rendah <i>Small size/Less power consumption</i>			
	Fungsi kerja <i>Work function</i>	Rendah <i>Low</i>	Lebih cekap mengesan foton/ Lebih sensitif <i>More effective to detect photon/Higher sensitivity</i>			
Pilihan/Choice : U					10	20

Bahagian C/Section C

Soalan Questions		Jawapan Answers			Sub markah Subs marks	Jumlah markah Total marks
11	(a)	(i)	Bilangan ayunan penuh dalam satu saat <i>Number of complete oscillations in one second</i>		1	
		(ii)	<ul style="list-style-type: none"> – Getaran tala bunyi menggetarkan zarah-zarah udara di sekeliling. <i>Vibration of the tuning fork vibrates air particles around it.</i> – Apabila tala bunyi bergerak keluar, kawasan mampatan terhasil. <i>When the tuning fork moves outward, compression region is produced.</i> – Apabila tala bunyi bergerak ke dalam, kawasan regangan terhasil. <i>When the tuning fork moves inward, rarefaction region is produced.</i> – Satu siri mampatan dan regangan terhasil dan tenaga dipindahkan. <i>A series of compression and rarefaction is produced and energy is transferred.</i> 		4	
	(b)	<ul style="list-style-type: none"> – Amplitud getaran $d_1 < d_2$ <i>Amplitudes of vibration $d_1 < d_2$</i> – Nilai puncak $a_1 < a_2$ <i>Peak values $a_1 < a_2$</i> – Semakin tinggi nilai-nilai puncak, semakin tinggi amplitud gelombang bunyi.//Apabila nilai-nilai puncak bertambah, amplitud bertambah. <i>The higher the peak values, the higher the amplitude of sound waves.//When the peak values increases, the amplitude increases.</i> – Semakin tinggi nilai-nilai puncak, semakin tinggi kenyaringan bunyi. <i>The higher the peak values, the higher the loudness of the sound.</i> – Semakin tinggi amplitud gelombang, semakin tinggi kenyaringan bunyi.//Kenyaringan bunyi berkadar terus dengan amplitud gelombang. <i>The higher the amplitude of the wave, the higher the loudness of the sound.//The loudness of the sound is directly proportional to the amplitude of the wave.</i> 		5		

Soalan Questions		Jawapan Answers			Sub markah Subs marks	Jumlah markah Total marks
(c)		Aspek Aspect	Modifikasi Modification	Penerangan Explanation		
	Jenis gelombang dipancar <i>Types of wave transmitted</i>	Gelombang mikro <i>Microwave</i>	Boleh merambat jauh ke satelit// Tenaga tinggi//Frekuensi tinggi <i>Able to propagate far to the satellite// High energy//High frequency</i>			
	Kedudukan penerima <i>Position of receiver</i>	Di bahagian atas dron <i>On the top of the drone</i>	Mudah terima pantulan daripada satelit <i>Easy to receive reflection from the satellite</i>			
	Bilangan bilah kipas <i>Number of propellers</i>	Banyak <i>More</i>	Daya angkat lebih tinggi <i>Higher or greater lift force</i>			
	Saiz tangki baja <i>Size of fertiliser tank</i>	Besar <i>Big</i>	Kuantiti baja lebih banyak// Semburan kawasan yang lebih luas <i>More quantity of fertiliser//Wider spray area</i>			
	Komponen tambahan <i>Additional component</i>	Kamera <i>Camera</i>	Dapat meninjau keadaan tanaman/ kawasan pertanian <i>Can inspect the condition of crops/ agricultural area</i>			
GPS		Boleh mengukur luas/jarak/lokasi <i>Able to measure the area/distance/ location</i>				
					10	20

KERTAS 1 / Paper 1

- 1 B Pecutan/*Acceleration*, $a = \frac{v - u}{t}$
 $= \frac{l}{t}$
- 2 D Kecerunan graf/*Gradient of graph*, $m = \frac{0 - 10}{5 - 0}$
 $= -2$
 Pintasan paksi-y/*y-intercept* = 10
 Persamaan garis lurus/*Linear equation*:
 $y = mx + c$
 $P = -2Q + 10$
- 3 B Gerakan ke bawah/*Downward motion* → Halaju bertambah/*Velocity increases*
 Gerakan ke atas/*Upward motion* → Halaju berkurang/*Velocity decreases*
- 4 A Hidangan mengekalkan keadaan asal iaitu pegun di atas meja.
The dishes remain its initial state at rest on the table.
- 5 A Masa hentaman berbeza, maka semua kuantiti yang melibatkan masa akan berbeza.
The time of impact is different, hence all quantities involve time will be different.
- 6 B Hukum Gerakan Newton Kedua, $F = ma$
Newton's Second Law of Motion, F = ma
- 7 C Apabila masa hentaman dipanjangkan, daya impuls yang terhasil dikurangkan.
When the time of impact is prolonged, the impulsive force produced is decreased/lowered.
- 8 C Halaju lepas/*Escape velocity*, $v = \sqrt{\frac{2Gm}{r}}$
- 9 A Objek dengan muatan haba tentu tinggi perlu serap lebih banyak haba untuk meningkatkan suhu.
An object with a higher specific heat capacity requires to absorb more heat to raise its temperature.
- 10 D $Pt = mc\theta$
 $(1\ 000)(3 \times 60) = (2)(c)(80 - 30)$
 $c = 1\ 800\ \text{J kg}^{-1}\ \text{°C}^{-1}$
- 11 D Ais melebur dan mengukus makanan melibatkan haba pendam tentu, iaitu perubahan fasa bahan pada suhu tetap.
Melting of ice and steaming food involve specific latent heat, which is the change of phase at constant temperature.
- 12 A Tekanan berkurang apabila naik ke permukaan, maka isi padu gelembung bertambah.
Pressure decreases when rises to the water surface, hence the volume of bubble increases.
- 13 C Jarak mengufuk ayunan tidak berubah, maka tempoh ayunan tidak berubah.
The horizontal distance of oscillation is constant, hence the period of oscillation is constant.
- 14 A Kawasan X ialah kawasan dalam, panjang gelombang dan laju gelombang adalah tinggi.
Region X is a deep region, the wavelength and the speed of the wave is high.
- 15 D Ketuhar gelombang mikro menggunakan gelombang mikro untuk memasak.
Microwave oven uses microwave to cook food.

16 C
$$\frac{\sin i}{\sin r} = \frac{\text{Kedalaman sebenar/Real depth (H)}}{\text{Kedalaman ketara/Apparent depth (h)}}$$

$$\frac{\sin 50^\circ}{\sin 35^\circ} = \frac{H}{2.0}$$

$$H = 2.67 \text{ m}$$

17 D
$$n = \frac{1}{\sin c}$$

$$1.52 = \frac{1}{\sin c}$$

$$c = 41.14^\circ$$

$i = 45^\circ$, di mana $i > c$, maka pantulan dalam penuh berlaku.
 $i = 45^\circ$, where $i > c$, hence total internal reflection occurs.

18 C
$$\frac{v}{u} = \frac{h_i}{h_o}$$

$$\frac{20}{10} = \frac{4}{h_o}$$

$$h_o = 2 \text{ cm}$$

- 19 B A – Kanta objektif dan kanta mata kedua-dua kanta cembung.
Objective lens and eyepiece are both convex lenses.
 B – Kuasa kanta objektif < kuasa kanta mata
Power of objective lens < power of eyepiece
 C, D – Pelarasan normal, $L = f_o + f_c$
Normal adjustment, $L = f_o + f_c$

- 20 D Kapal terbang mengalami pecutan pada ketinggian malar, maka tujahan > seretan, daya angkat = berat
The aeroplane experiences acceleration at a constant altitude, where thrust > drag, lift force = weight

21 B
$$F_{\text{net}} = ma$$

$$60 \text{ kos} / \cos 30^\circ = 2.0a$$

$$a = 25.98 \text{ m s}^{-2}$$

- 22 C Kapal terapung pegun di laut: Daya apungan = Berat kapal
A ship floating at rest on the sea: Buoyant force = Weight of the ship

- 23 A Spring S: sesiri/series, pemanjangan/extension = 3x
 Spring T: selari/parallel, pemanjangan/extension = $\frac{x}{3}$
 Spring U: kombinasi/combination, pemanjangan/extension = $\frac{x}{2} + x$

- 24 B Apabila kedalaman bertambah, tekanan bertambah.
When depth increases, pressure increases.

25 A
$$P_x = P_{\text{atm}} + h\rho g$$

$$P_y = P_{\text{atm}}$$

$$P_z = P_{\text{atm}} - h\rho g$$

- 26 A
$$P_{\text{gas}} = P_{\text{atm}} - h\rho g$$

Tekanan atmosfera > tekanan gas, cecair X ditolak ke bawah.
Atmospheric pressure > gas pressure, liquid X is pushed down the column.

- 27 C Jengkaut menggunakan aplikasi sistem hidraulik.
An excavator applies hydraulic system.
- 28 C Ion positif mempunyai jisim yang lebih besar, maka nyalaan lilin tersebar ke plat K lebih besar.
Positive ions have greater mass, hence the spread of flame towards plate K is bigger.
- 29 D Litar bersiri: V berkadar terus dengan R.
Series circuit: V is directly proportional to R.
- 30 B $E = Pt$
 $= 0.06 \text{ kW} \times 0.5 \text{ jam/hour}$
 $= 0.03 \text{ kWj/kWh}$
- 31 C Gunakan petua tangan kiri Fleming.
Use Fleming's left-hand rule.
- 32 A Solenoid: Gunakan petua genggam tangan kanan, Q ialah kutub Utara.
Solenoid: Use the right-hand grip rule. Q is North pole.
Bar magnet: Menurut Hukum Lenz, magnet yang bergerak masuk ke dalam solenoid mempunyai kekutuban sama.
Magnet bar: According to Lenz Law, magnet that moves into solenoid have same polarity.
- 33 A Transformer unggul/Ideal transformer:
 $I_p V_p = I_s V_s$
 $I_p(240) = 48$
 $I_p = 0.2 \text{ A}$
- 34 A Ciri-ciri elektron: Bercas negatif, bergerak dalam garis lurus, dipesongkan oleh medan elektrik dan medan magnet
Characteristics of electrons: Negative charges, travel in a straight line, deflected by electric and magnetic fields
- 35 B Diod dipincang songsang, arus tidak mengalir. Menyongsangkan sambungan bateri akan menjadikan diod dipincang depan.
Diode is reverse biased, current does not flow. Reversing the connection of the battery will turn the diode to forward biased.
- 36 B Litar dipincang songsang, arus tapak tidak mengalir dan transistor dimatikan.
Circuit is reverse biased, base current does not flow and transistor is switched off.
- 37 A $T_{\frac{1}{2}} = 15 \text{ min}$
Bilangan separuh hayat dalam satu jam/Number of half-life in one hour = $4 T_{\frac{1}{2}}$
 $800 \text{ g} \rightarrow 400 \text{ g} \rightarrow 200 \text{ g} \rightarrow 100 \text{ g} \rightarrow 50 \text{ g}$
- 38 D Dua nukleus ringan bergabung membentuk elemen baharu dan mengeluarkan tenaga nuklear.
Two lighter nuclei combined producing a new element and releases nuclear energy.
- 39 A $P = nhf$
 $10 = n(6.63 \times 10^{-34})(5.49 \times 10^{14})$
 $n = 2.75 \times 10^{19} \text{ foton/photon}$
- 40 C Frekuensi foton yang disinarkan lebih rendah daripada frekuensi ambang platinum.
The frequency of photon irradiated is lower than the threshold frequency of platinum.

Bahagian A/Section A

Soalan Questions		Jawapan Answers	Sub markah Subs marks	Jumlah markah Total marks
1	(a)	✓ – kuantiti skalar <i>scalar quantity</i>	1	4
	(b)	$T = \frac{24}{20}$ = 1.2 s	2	
	(c)	Bertambah/ <i>Increases</i>	1	
2	(a)	– Mempunyai tenaga dan momentum/ <i>It has energy and momentum</i> – Bergerak dengan kelajuan cahaya dalam vakum <i>Moves with speed of light in vacuum</i> – Tidak mempunyai cas elektrik/ <i>It has no electric charge</i> (Mana-mana satu/ <i>Any one</i>)	1	5
	(b)	– Tidak/ <i>No</i> – Keseluruhannya dilihat sebagai kesan gelombang <i>Is wholly seen as waves effect</i>	2	
	(c)	$n = \frac{P\lambda}{hc}$ $= \frac{(1 \times 10^3)(6.7 \times 10^{-2})}{(6.63 \times 10^{-34})(3 \times 10^8)}$ = 3.37×10^{26} foton per saat/ <i>photons per second</i>	2	
3	(a)	(i) Barometer merkuri/ <i>Mercury barometer</i>	1	6
		(ii) Mempunyai ketumpatan tinggi//Legap//Tidak melekat pada tiub kaca <i>Has higher density//Opaque//Does not stick to the glass tube</i> (Mana-mana satu/ <i>Any one</i>)	1	
	(b)	(i) 76 cm Hg	1	
		(ii) $P = \rho gh$ = (13 600)(9.81)(0.76) = 1.01×10^5 Pa	2	
		(iii) Berkurang/ <i>Decreases</i>	1	
4	(a)	Nukleus tidak stabil/ <i>Unstable nuclei</i>	1	4
	(b)	(i) ${}_{83}^{214}\text{Bi} \rightarrow {}_{81}^{210}\text{Tl} + {}_2^4\text{He}$	1	
		(ii) Bi ialah nukleus yang tidak stabil//Untuk menjadi lebih stabil <i>Bi is an unstable nucleus//To become more stable</i>	1	
		(iii) Zarah alfa/ <i>Alpha particles</i> = 2, Zarah beta/ <i>Beta particles</i> = 3	1	
	(c)	X: 82, Y: 4	2	

Soalan Questions		Jawapan Answers	Sub markah Subs marks	Jumlah markah Total marks
	(d)	$N = \left(\frac{1}{2}\right)^n N_0$ $= \left(\frac{1}{2}\right)^5 (200)$ $= 6.25 \text{ g}$ <p style="text-align: center;">atau / or</p> Bilangan separuh hayat/Number of half-life, $T_{\frac{1}{2}}$ $= \frac{98.5}{19.7}$ $= 5$ Maka/Hence, $200 \text{ g} \rightarrow 100 \text{ g} \rightarrow 50 \text{ g} \rightarrow 25 \text{ g} \rightarrow 12.5 \text{ g} \rightarrow 6.25 \text{ g}$	3	9
5	(a)	Imej yang tidak dapat ditayangkan pada skrin <i>Image that cannot be cast on a screen</i>	1	9
	(b)	(i) Ketebalan kanta dalam Rajah 5(b) > Rajah 5(a). (atau sebaliknya) <i>The thickness of the lens in Diagram 5(b) > Diagram 5(a). (vice versa)</i>	1	
		(ii) Jarak fokus kanta dalam Rajah 5(b) < Rajah 5(a). (atau sebaliknya) <i>The focal length of the lens in Diagram 5(b) < Diagram 5(a). (vice versa)</i>	1	
		(iii) Saiz imej yang terbentuk dalam Rajah 5(b) > Rajah 5(a). (atau sebaliknya) <i>The size of the image formed in Diagram 5(b) > Diagram 5(a). (vice versa)</i>	1	
	(c)	(i) Semakin bertambah ketebalan kanta, semakin berkurang jarak fokus kanta. (atau sebaliknya) <i>The thickness of the lens increases, the focal length of the lens decreases. (vice versa)</i>	1	
		(ii) Semakin bertambah ketebalan kanta, semakin bertambah saiz imej yang terbentuk. (atau sebaliknya) <i>The thickness of the lens increases, the size of the image formed increases. (vice versa)</i>	1	
	(d)	Saiz imej tidak berubah, kecerahan imej berkurang. <i>The size of the image unchanged, the brightness of the image decreases.</i>	2	
(e)	Pembiasan/Refraction	1		
6	(a)	Daya per unit luas/Force per unit area	1	9
	(b)	(i) Kedalaman pili dari permukaan air dalam Rajah 6(b) > Rajah 6(a). (atau sebaliknya) <i>The depth of the tap from the water surface in Diagram 6(b) > Diagram 6(a). (vice versa)</i>	1	
		(ii) Tekanan air pada pili dalam Rajah 6(b) > Rajah 6(a). (atau sebaliknya) <i>The water pressure at the tap in Diagram 6(b) > Diagram 6(a). (vice versa)</i>	1	
		(iii) Jarak mengufuk pancutan air dalam Rajah 6(b) > Rajah 6(a). (atau sebaliknya) <i>The horizontal distance of the water spurts out in Diagram 6(b) > Diagram 6(a). (vice versa)</i>	1	

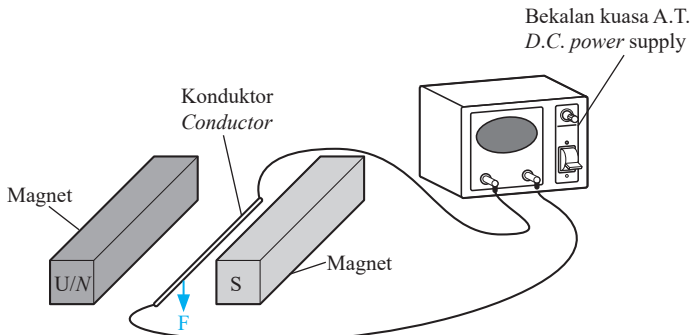
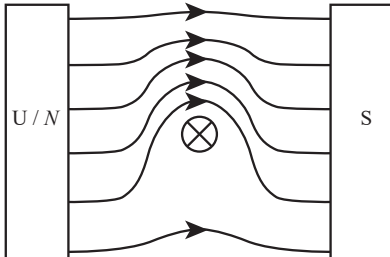
Soalan Questions		Jawapan Answers	Sub markah Subs marks	Jumlah markah Total marks
(c)	(i)	Semakin bertambah kedalaman air, semakin bertambah tekanan air. (atau sebaliknya) <i>When the depth of the water increases, the water pressure increases. (vice versa)</i>	1	9
	(ii)	Semakin bertambah tekanan air, semakin bertambah jarak mengufuk pancutan air. (atau sebaliknya) <i>When the water pressure increases, the horizontal distance of the water spurts out increases. (vice versa)</i>	1	
(d)	(i)	Bertambah/Increases	1	9
	(ii)	Tekanan bertambah./Pressure increases.// $P = P_{\text{atm}} + h\rho g$	2	
7	(a)	Kawasan di sekitar magnet yang merasai daya magnet <i>A region around the magnet which experiences the magnetic force</i>	1	9
	(b) (i)		1	
	(ii)	Peraturan tangan kiri Fleming/ <i>Fleming's left-hand Rule</i>	1	
	(iii)		1	
(c)	(i)	Banyak/More Kekuatan medan magnet bertambah.//Magnitud daya bertambah.//Arus bertambah. <i>Stronger magnetic field.//Magnitude of force increases.//Current increases.</i>	2	9
	(ii)	Banyak/More Magnitud daya bertambah. <i>Magnitude of force increases.</i>	2	
(d)		U	1	9

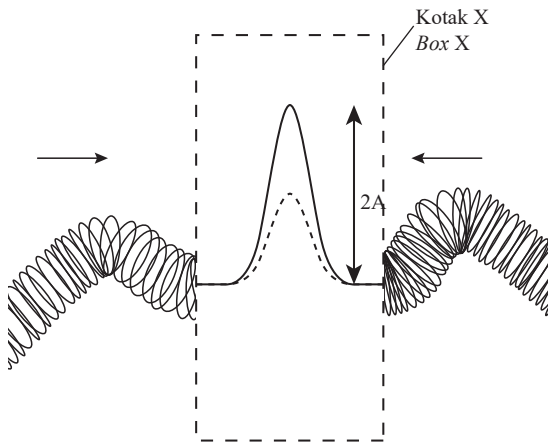
Soalan Questions			Jawapan Answers	Sub markah Subs marks	Jumlah markah Total marks
8	(a)	(i)	Gelombang melintang//Gelombang progresif <i>Transverse waves//Progressive waves</i>	1	
		(ii)	$v = f\lambda$ $= 6 \times 7.5$ $= 45 \text{ cm s}^{-1}$	2	
	(b)	(i)		1	
		(ii)	Interferens membina/ <i>Constructive interference</i>	1	
	(c)	(i)	Di kawasan teluk/ <i>At the bay</i> Air lebih tenang.//Tenaga gelombang lebih rendah. <i>The water is calmer.//Waves energy is low.</i>	2	
		(ii)	Benteng dengan celah/lekuk/tinggi/kuat/ <i>Barrier with slit/dent/high/strong</i> Pembelauan berlaku.//Gelombang tersebar.//Amplitud berkurang.// Tenaga berkurang. <i>Diffraction occurs.//Waves spread.//Amplitude decreases.//Energy decreases.</i>	2	
					9

Bahagian B/Section B

Soalan Questions		Jawapan Answers	Sub markah Subs marks	Jumlah markah Total marks												
9	(a)	Prinsip Pascal/Pascal Principle	1	20												
	(b)	<ul style="list-style-type: none"> – Daya yang dikenakan pada omboh kecil dengan luas permukaan kecil menghasilkan tekanan tinggi, $P = \frac{F}{A}$. <i>Force applied to the small piston with a small surface area, produces high pressure, $P = \frac{F}{A}$.</i> – Tekanan dipindahkan secara seragam pada semua arah dalam bendalir. <i>Pressure is transmitted uniformly in all direction throughout the fluid.</i> – Pada omboh besar, tekanan bertindak pada luas permukaan omboh besar, menghasilkan daya angkat yang besar, $F = PA$. <i>At the large piston, pressure acts on the surface area of the large piston, a larger lifting force is produced, $F = PA$.</i> – Apabila luas keratan rentas bertambah, daya angkat bertambah. <i>When the cross-sectional area increases, the lifting force increases.</i> 	4													
	(c)	<table border="1" style="width: 100%; border-collapse: collapse;"> <thead> <tr> <th style="text-align: center;">Ciri-ciri/Characteristics</th> <th style="text-align: center;">Sebab/Reason</th> </tr> </thead> <tbody> <tr> <td>M1: Jenis bendalir – Minyak <i>Type of fluid – Oil</i></td> <td>M2: Tidak boleh dimampatkan. <i>Cannot be compressed.</i></td> </tr> <tr> <td>M3: Kadar didih bendalir hidraulik – Rendah <i>Rate of boiling of hydraulic fluid – Low</i></td> <td>M4: Tidak mudah tersejat. <i>Not easily vaporised.</i></td> </tr> <tr> <td>M5: Luas keratan rentas omboh induk– Kecil <i>Cross-sectional area of master piston – Small</i></td> <td>M6: Menghasilkan tekanan yang besar. <i>Produces high pressure.</i></td> </tr> <tr> <td>M7: Luas keratan rentas omboh hamba – Besar <i>Cross-sectional area of slave piston – Big</i></td> <td>M8: Menghasilkan daya yang besar. <i>Produces high force.</i></td> </tr> <tr> <td>M9: Pilih L. <i>Choose L.</i></td> <td>M10: Kombinasi M1, M3, M5, M7 atau M2, M4, M6 dan M8. <i>Combination of M1, M3, M5, M7 or M2, M4, M6 and M8.</i></td> </tr> </tbody> </table>	Ciri-ciri/Characteristics		Sebab/Reason	M1: Jenis bendalir – Minyak <i>Type of fluid – Oil</i>	M2: Tidak boleh dimampatkan. <i>Cannot be compressed.</i>	M3: Kadar didih bendalir hidraulik – Rendah <i>Rate of boiling of hydraulic fluid – Low</i>	M4: Tidak mudah tersejat. <i>Not easily vaporised.</i>	M5: Luas keratan rentas omboh induk– Kecil <i>Cross-sectional area of master piston – Small</i>	M6: Menghasilkan tekanan yang besar. <i>Produces high pressure.</i>	M7: Luas keratan rentas omboh hamba – Besar <i>Cross-sectional area of slave piston – Big</i>	M8: Menghasilkan daya yang besar. <i>Produces high force.</i>	M9: Pilih L. <i>Choose L.</i>	M10: Kombinasi M1, M3, M5, M7 atau M2, M4, M6 dan M8. <i>Combination of M1, M3, M5, M7 or M2, M4, M6 and M8.</i>	10
	Ciri-ciri/Characteristics	Sebab/Reason														
	M1: Jenis bendalir – Minyak <i>Type of fluid – Oil</i>	M2: Tidak boleh dimampatkan. <i>Cannot be compressed.</i>														
	M3: Kadar didih bendalir hidraulik – Rendah <i>Rate of boiling of hydraulic fluid – Low</i>	M4: Tidak mudah tersejat. <i>Not easily vaporised.</i>														
M5: Luas keratan rentas omboh induk– Kecil <i>Cross-sectional area of master piston – Small</i>	M6: Menghasilkan tekanan yang besar. <i>Produces high pressure.</i>															
M7: Luas keratan rentas omboh hamba – Besar <i>Cross-sectional area of slave piston – Big</i>	M8: Menghasilkan daya yang besar. <i>Produces high force.</i>															
M9: Pilih L. <i>Choose L.</i>	M10: Kombinasi M1, M3, M5, M7 atau M2, M4, M6 dan M8. <i>Combination of M1, M3, M5, M7 or M2, M4, M6 and M8.</i>															
(d)	(i)	$P = \frac{F}{A}$ $= \frac{30 \text{ N}}{3 \text{ cm}^2}$ $= 10 \text{ N cm}^{-2}$	2													
	(ii)	$F = PA$ $= 10 \text{ N cm}^{-2} \times 12 \text{ cm}^2$ $= 120 \text{ N}$	3													
10	(a)	Suhu kedua-dua objek yang bersentuhan terma adalah sama dan kadar pemindahan/pengaliran haba bersih adalah sifar. <i>Temperature of both objects in thermal contact are the same, and the net rate of heat transfer/flow is zero.</i>	1													

Soalan Questions		Jawapan Answers	Sub markah Subs marks	Jumlah markah Total marks												
(b)	(i)	<ul style="list-style-type: none"> – Haba dipindahkan dari blok logam K yang panas ke air yang sejuk. <i>Heat is transferred from hot metal block K to cold water.</i> – Merkuri mengembang./Isi padu merkuri bertambah. <i>Mercury expands./Volume of mercury increases.</i> – Suhu termometer sama dengan suhu air. <i>The temperature of thermometer equals to the temperature of water.</i> 	3													
	(ii)	<ul style="list-style-type: none"> Bagi mengelakkan haba hilang ke persekitaran. <i>To prevent heat lost to the surroundings.</i> 	1													
(c)	(i)	$\theta = 50^{\circ}\text{C} - 30^{\circ}\text{C}$ $= 20^{\circ}\text{C}$														
	(ii)	$Q = mc\theta$ $= (0.1)(4\ 200)(20)$ $= 8\ 400\ \text{J}$														
	(iii)	Haba dibebaskan oleh blok logam K = Haba diserap oleh air <i>Heat released by metal block K = Heat absorbed by water</i> $mc\theta = 8\ 400$ $0.6 \times c \times (130 - 50) = 8\ 400$ $c = 175\ \text{J kg}^{-1}\ ^{\circ}\text{C}^{-1}$			5											
(d)	<table border="1"> <thead> <tr> <th>Cadangan/Suggestion</th> <th>Sebab/Reason</th> </tr> </thead> <tbody> <tr> <td>M1: Muatan haba tentu badan – Rendah <i>Specific heat capacity of body – Low</i></td> <td>M2: Cepat panas//Suhu naik dengan cepat <i>Heat up quickly//Temperature rises quickly</i></td> </tr> <tr> <td>M3: Muatan haba tentu pemegang – Tinggi <i>Specific heat capacity of handle – High</i></td> <td>M4: Lambat panas//Suhu naik dengan perlahan <i>Heat up slowly//Temperature rises slowly</i></td> </tr> <tr> <td>M5: Permukaan badan – Gelap <i>Body surface – Dark</i></td> <td>M6: Serap haba dengan baik//Pemantul haba yang lemah <i>Good heat absorber//Poor heat reflector</i></td> </tr> <tr> <td>M7: Bentuk pemegang – Langsing <i>Shape of handle – Slim</i></td> <td>M8: Memberi cengkaman kuat//Elakkan tergelincir <i>Provide strong grip//Prevent slipping</i></td> </tr> <tr> <td>M9: Pilih model Z. <i>Choose model Z.</i></td> <td>M10: Kombinasi M1, M3, M5, M7 atau M2, M4, M6 dan M8. <i>Combination of M1, M3, M5, M7 or M2, M4, M6 and M8.</i></td> </tr> </tbody> </table>		Cadangan/Suggestion	Sebab/Reason	M1: Muatan haba tentu badan – Rendah <i>Specific heat capacity of body – Low</i>	M2: Cepat panas//Suhu naik dengan cepat <i>Heat up quickly//Temperature rises quickly</i>	M3: Muatan haba tentu pemegang – Tinggi <i>Specific heat capacity of handle – High</i>	M4: Lambat panas//Suhu naik dengan perlahan <i>Heat up slowly//Temperature rises slowly</i>	M5: Permukaan badan – Gelap <i>Body surface – Dark</i>	M6: Serap haba dengan baik//Pemantul haba yang lemah <i>Good heat absorber//Poor heat reflector</i>	M7: Bentuk pemegang – Langsing <i>Shape of handle – Slim</i>	M8: Memberi cengkaman kuat//Elakkan tergelincir <i>Provide strong grip//Prevent slipping</i>	M9: Pilih model Z. <i>Choose model Z.</i>	M10: Kombinasi M1, M3, M5, M7 atau M2, M4, M6 dan M8. <i>Combination of M1, M3, M5, M7 or M2, M4, M6 and M8.</i>	10	20
Cadangan/Suggestion	Sebab/Reason															
M1: Muatan haba tentu badan – Rendah <i>Specific heat capacity of body – Low</i>	M2: Cepat panas//Suhu naik dengan cepat <i>Heat up quickly//Temperature rises quickly</i>															
M3: Muatan haba tentu pemegang – Tinggi <i>Specific heat capacity of handle – High</i>	M4: Lambat panas//Suhu naik dengan perlahan <i>Heat up slowly//Temperature rises slowly</i>															
M5: Permukaan badan – Gelap <i>Body surface – Dark</i>	M6: Serap haba dengan baik//Pemantul haba yang lemah <i>Good heat absorber//Poor heat reflector</i>															
M7: Bentuk pemegang – Langsing <i>Shape of handle – Slim</i>	M8: Memberi cengkaman kuat//Elakkan tergelincir <i>Provide strong grip//Prevent slipping</i>															
M9: Pilih model Z. <i>Choose model Z.</i>	M10: Kombinasi M1, M3, M5, M7 atau M2, M4, M6 dan M8. <i>Combination of M1, M3, M5, M7 or M2, M4, M6 and M8.</i>															

Bahagian C/Section C

Soalan Questions		Jawapan Answers	Sub markah Subs marks	Jumlah markah Total marks										
11	(a)	12 J tenaga dihasilkan dalam 1 saat apabila beroperasi pada 6 V. <i>12 J of energy is produced in 1 second when being operated at 6 V.</i>	1											
	(b)	(i) – Rajah 11.1(a) ialah litar bersiri, Rajah 11.1(b) ialah litar selari. <i>Diagram 11.1(a) is a series circuit, Diagram 11.1(b) is a parallel circuit.</i> – Kecerahan mentol dalam Rajah 11.1(b) > Rajah 11.1(a). (atau sebaliknya) <i>The brightness of the bulbs in Diagram 11.1(b) > Diagram 11.1(a). (vice versa)</i> – Arus yang mengalir dalam litar Rajah 11.1(b) > Rajah 11.1(a). (atau sebaliknya) <i>The current flows in the circuit in Diagram 11.1(b) > Diagram 11.1(a). (vice versa)</i>	5											
		(ii) – Litar selari, kecerahan mentol bertambah. <i>Parallel circuit, the brightness of the bulbs increases.</i> – Semakin berkurangan rintangan berkesan, semakin bertambah arus yang mengalir. (atau sebaliknya) <i>The effective resistance decreases, the current flows in the circuit increases. (vice versa)</i>												
	(c)	– Panjang filamen lebih tinggi. <i>Length of filament is higher.</i> – Rintangan filamen lebih tinggi/bertambah. <i>Resistance of filament is higher/increases.</i> – Hasilkan tenaga haba yang banyak/tinggi. <i>Produces more/higher heat energy.</i> – Tenaga haba ditukarkan kepada tenaga cahaya. <i>Heat energy is converted to light energy.</i>	4											
(d)	<table border="1"> <thead> <tr> <th>Cadangan/Suggestion</th> <th>Sebab/Reason</th> </tr> </thead> <tbody> <tr> <td>M1: Bahan pemanas – Nikrom/ Tungsten <i>Material of heater – Nichrome/Tungsten</i></td> <td>M2: Rintangan tinggi//Haba tinggi <i>High resistance//High heat</i></td> </tr> <tr> <td>M3: Diameter dawai pemanas – Kecil <i>Diameter of heater wire – Small</i></td> <td>M4: Rintangan tinggi//Haba tinggi <i>High resistance//High heat</i></td> </tr> <tr> <td>M5: Takat lebur pemanas – Tinggi <i>Melting point of heater – High</i></td> <td>M6: Tidak mudah lebur/cair <i>Does not melt easily</i></td> </tr> <tr> <td>M7: Kadar pengoksidaan/ pengaratan pemanas – Rendah <i>Rate of oxidation/rusting of heater – Low</i></td> <td>M8: Tidak mudah karat//Tidak rapuh//Tahan lama <i>Does not easily rust//Not corrode//Long lasting</i></td> </tr> <tr> <td>M9: Guna termostat. <i>Use thermostat.</i></td> <td>M10: Kawal suhu. <i>Controls temperature.</i></td> </tr> </tbody> </table>	Cadangan/Suggestion	Sebab/Reason	M1: Bahan pemanas – Nikrom/ Tungsten <i>Material of heater – Nichrome/Tungsten</i>	M2: Rintangan tinggi//Haba tinggi <i>High resistance//High heat</i>	M3: Diameter dawai pemanas – Kecil <i>Diameter of heater wire – Small</i>	M4: Rintangan tinggi//Haba tinggi <i>High resistance//High heat</i>	M5: Takat lebur pemanas – Tinggi <i>Melting point of heater – High</i>	M6: Tidak mudah lebur/cair <i>Does not melt easily</i>	M7: Kadar pengoksidaan/ pengaratan pemanas – Rendah <i>Rate of oxidation/rusting of heater – Low</i>	M8: Tidak mudah karat//Tidak rapuh//Tahan lama <i>Does not easily rust//Not corrode//Long lasting</i>	M9: Guna termostat. <i>Use thermostat.</i>	M10: Kawal suhu. <i>Controls temperature.</i>	10
Cadangan/Suggestion	Sebab/Reason													
M1: Bahan pemanas – Nikrom/ Tungsten <i>Material of heater – Nichrome/Tungsten</i>	M2: Rintangan tinggi//Haba tinggi <i>High resistance//High heat</i>													
M3: Diameter dawai pemanas – Kecil <i>Diameter of heater wire – Small</i>	M4: Rintangan tinggi//Haba tinggi <i>High resistance//High heat</i>													
M5: Takat lebur pemanas – Tinggi <i>Melting point of heater – High</i>	M6: Tidak mudah lebur/cair <i>Does not melt easily</i>													
M7: Kadar pengoksidaan/ pengaratan pemanas – Rendah <i>Rate of oxidation/rusting of heater – Low</i>	M8: Tidak mudah karat//Tidak rapuh//Tahan lama <i>Does not easily rust//Not corrode//Long lasting</i>													
M9: Guna termostat. <i>Use thermostat.</i>	M10: Kawal suhu. <i>Controls temperature.</i>													

KERTAS 1 / Paper 1

- 1 A Berat/Weight = N, Daya/Force = N, Tekanan/Pressure = Pa
- 2 C Kuantiti asas: Jarak, jisim, masa, arus elektrik, suhu termodinamik, keamatan berluminesiti dan kuantiti bahan
Base quantities: Length, mass, time, electric current, thermodynamic temperature, luminous intensity and amount of substance
- 3 D Neraca spring digunakan untuk mengukur berat.
Spring balance is used to measure weight.
- 4 C Merujuk kepada graf Hukum Boyle, graf garis lurus P melawan $\frac{1}{V}$ yang bermula dari asalan menunjukkan P berkadar songsang dengan V.
Referring to the graph for Boyle's Law, a straight line graph of P against $\frac{1}{V}$ which started from the origin shows that P is inversely proportional to V.
- 5 B
$$a = \frac{v - u}{(n - 1)t}$$

$$= \frac{\frac{5}{0.02} - \frac{2}{0.02}}{(5 - 1) \times 0.02}$$

$$= 1\,875 \text{ cm s}^{-2}$$
- 6 B Sesaran/Displacement, s
 = Garis lurus/Straight line of PS
 $= \sqrt{6^2 + 8^2}$
 = 10 km
- 7 B Bola mengalami jatuh bebas mengikut pecutan graviti Bumi di mana halajunya bertambah. Menurut $E_k = \frac{1}{2} mv^2$, apabila halaju bertambah, tenaga kinetik bertambah.
The ball experienced free fall following the Earth's gravitational acceleration where its velocity increases. According to $E_k = \frac{1}{2} mv^2$, when velocity increases, kinetic energy increases.
- 8 B Kedudukan KL menunjukkan halaju malar iaitu pecutan sifar.
Position KL shows uniform velocity where acceleration is zero.
- 9 C Daya boleh mengubah laju, bentuk, saiz dan arah pergerakan sesuatu objek, tetapi bukan jisimnya.
A force can change the speed, shape, size and direction of motion of an object, but not its mass.
- 10 B Hukum Kepler Ketiga/Kepler's Third Law: $T^2 \propto r^3$
- 11 D Laju linear/Linear speed, $v = \sqrt{\frac{Gm}{r}}$

$$= \sqrt{\frac{(6.67 \times 10^{-11})(5.98 \times 10^{24})}{(6.37 \times 10^6 + 613 \times 10^3)}}$$

$$= 7.56 \times 10^3 \text{ m s}^{-1}$$
- 12 C Satelit geopegun sentiasa ditarik ke arah graviti Bumi.
Geostationary satellite is always pulled towards the Earth's gravity.

- 13 C** Apabila keseimbangan terma dicapai, kadar bersih aliran haba antara dua jasad yang bersentuhan terma adalah sifar dan suhu kedua-dua jasad adalah sama.
When thermal equilibrium is reached, the net flow of heat between the two bodies is zero and the temperature of both bodies are equal.
- 14 D** $Pt = mc\theta$
 $(1\ 000)(60) = (3)(400) \times \theta$
 $\theta = 50^\circ\text{C}$
 Suhu akhir, T
Final temperature, T
 $= 25^\circ\text{C} + 50^\circ\text{C}$
 $= 75^\circ\text{C}$
- 15 B** Menurut Hukum Charles, isi padu berkadar terus dengan suhu bagi gas berjisim malar pada tekanan tetap. Pertambahan suhu menyebabkan pertambahan tenaga kinetik molekul udara.
According to Charles Law, volume is directly proportional to the temperature for a fixed mass gas at a constant pressure. The increasing in temperature causes the increasing in kinetic energy of the air molecules.
- 16 D** $\frac{P_1}{T_1} = \frac{P_2}{T_2}$
 $\frac{210}{300} = \frac{230}{T_2}$
 $T_2 = 328.57\ \text{K}$
 $= (328.57 - 273)^\circ\text{C}$
 $= 55.57^\circ\text{C}$
- 17 B** Ciri-ciri pantulan gelombang bunyi: Frekuensi, panjang gelombang dan laju gelombang tidak berubah, sudut tuju = sudut pantulan
Characteristics of reflection of sound wave: The frequency, wavelength and speed of waves unchanged, angle of incidence = angle of reflection
- 18 B** Aplikasi sinaran ultraungu: bahan pengeras dalam tampalan gigi, mengesan keaslian wang kertas, rawatan jaundis pada bayi, penyulingan air minuman, pensterilan alatan pembedahan dan makanan, perangkap serangga
Applications of ultraviolet radiation: hardening material for tooth filling, determine the authenticity of currency notes, treatment of jaundice in babies, purification of drinking water, sterilisation of surgical instruments and food, insect traps
- 19 C** Kuasa pembesaran teleskop/*Magnifying power of telescope:*
 $M = \frac{f_o}{f_c}$
 $f_o = 15 f_c$, diberi/*given* $f_o + f_c = 80\ \text{cm}$, maka/*hence* $f_o = 75\ \text{cm}$, $f_c = 5\ \text{cm}$
- 20 C** Cermin cekung ialah cermin penumpu. Sinar cahaya selari yang mengenai permukaan cermin akan dipantulkan ke titik fokus di hadapan cermin.
Concave mirror is a converging mirror. Parallel light rays directed at its surface will be reflected to the focal point in front of the mirror.
- 21 B** Indeks biasan medium X/*Refractive index of medium X*
 $n = \frac{\sin i \text{ (medium kurang tumpat/less dense medium)}}{\sin r \text{ (medium lebih tumpat/denser medium)}}$
 $= \frac{\sin 70^\circ}{\sin 40^\circ}$
 $= 1.46$

- 22 A** Tekanan cecair bertambah dengan pertambahan kedalaman, $P = \rho gh$.
The pressure in liquid increases when the depth increases, $P = \rho gh$.
- 23 B** Tekanan cecair dipengaruhi oleh ketumpatannya. Daripada $P = \rho gh$, ketumpatan cecair bertambah, tekanan cecair bertambah. Air menolak minyak zaitun ke bawah menunjukkan tekanannya lebih tinggi daripada minyak zaitun, maka ketumpatan air lebih tinggi daripada minyak zaitun. Tekanan atmosfera bertindak di kedua-dua tiub-U yang terbuka.
Pressure in liquid is affected by its density. From $P = \rho gh$, when density increases, pressure in liquid increases. The water pushes the olive oil downwards showing that its pressure is higher than the olive oil, hence the density of water is higher than olive oil. Atmospheric pressure acts on both open ends of the U-tube.
- 24 D** Apabila halaju purata molekul gas bertambah, kadar perlanggaran molekul gas dengan dinding dalam bekas bertambah, maka tekanan bertambah.
When the average velocity of gas molecules increases, the rate of collision between the gas molecules and the inner wall of the container increases, hence the pressure increases.
- 25 C** Sistem hidraulik mengaplikasikan prinsip Pascal di mana tekanan yang dikenakan oleh daya kecil F pada piston J dipindahkan secara seragam ke seluruh bahagian bendalir, maka tekanan di omboh J = tekanan di omboh K, dan beban W yang lebih besar daripada daya F mampu diangkat.
A hydraulic system uses Pascal's principle where the pressure exerted by a small force F at piston J will be transmitted uniformly throughout the fluid, hence the pressure at piston J = the pressure at piston K, and load W which is greater than force F is able to be lifted.
- 26 B** Daya apungan bertambah apabila ketumpatan air bertambah, $F_B = \rho gV$
Buoyant force increases when the density of water increases, $F_B = \rho gV$
- 27 D** Prinsip kerja Bernoulli melibatkan halaju dan tekanan bendalir di mana apabila halaju bendalir bertambah, tekanan pada bendalir berkurang dan sebaliknya.
Working principle of Bernoulli's involves the velocity and the pressure of fluid in which when the velocity of fluid increases, its pressure decreases and vice versa.
- 28 B** Apabila rintangan dalam litar berkurang, maka arus yang mengalir bertambah, bacaan ammeter bertambah.
When the resistance in the circuit decreases, the current flow increases, ammeter reading increases.
- 29 B** Apabila suis ditutup, litar menjadi lengkap. Beza keupayaan berkurang akibat rintangan dalam sel kering.
When the switch is switched on, the circuit is completed. Potential difference decreases due to the internal resistance in the dry cells.
- 30 D** Tenaga elektrik dipindahkan melalui kabel pada beza keupayaan yang tinggi dan arus yang rendah untuk mengurangkan kehilangan kuasa dalam kabel semasa pemindahan.
Electrical energy transmitted through the cables at high potential difference and low current to reduce power dissipated in the cables during transmission.
- 31 C** $\frac{24 \text{ W}}{P_{\text{input}}} \times 100\% = 40\%$, $P_{\text{input}} = 60 \text{ W}$
- 32 B** Dawai kuprum mempunyai rintangan yang rendah, teras besi lembut mudah dimagnet dan dinyahmagnet, manakala teras berlamin mengurangkan arus pusar.
Copper wire has low resistance, soft iron core is easily magnetised and demagnetised, while laminated core reduces eddy current.
- 33 D** Menggunakan nisbah beza keupayaan/Using the ratio of potential difference,
$$\frac{1}{5} = \frac{1\ 000}{R_M}$$
$$R_M = 5\ 000 \ \Omega$$

- 34 **D** Diod P akan menjadi pincang songsang dalam kedua-dua hala, maka arus tidak dapat mengalir.
Diode P will become reverse biased in both ways, hence current will not flow.
- 35 **B** Masa/Time = 80 min
1 200 → 600 → 300 → 150 → 75
Separuh hayat/*Half-life*, $T_{\frac{1}{2}}$
 $= \frac{80}{4}$
 $= 20 \text{ min}$
- 36 **D** Zarah alfa/*Alpha particle*, $\alpha = {}_2^4\text{He}$
Zarah beta/*Beta particle*, $\beta = {}_{-1}^0\text{e}$
- 37 **A** Rod pengawal yang diperbuat daripada boron atau kadmium mengawal kadar tindak balas berantai dengan menyerap neutron berlebihan.
Control rods made from boron or cadmium control the rate of chain reaction by absorbing excess neutrons.
- 38 **D** Memperkenalkan teori kuantum di mana tenaga cahaya wujud dalam bentuk paket tenaga yang diskrit.
Introduced quantum theory where light energy exists in a form of discrete energy packet.
- 39 **A** Berdasarkan teori kuantum Max Planck dan Albert Einstein, tenaga cahaya wujud dalam bentuk paket tenaga yang diskrit yang dikenali sebagai foton.
Based on Max Planck and Albert Einstein's quantum theory, light energy exists in a form of discrete energy packet known as photon.
- 40 **A** $E = W + K$
 $4.96 = 4.36 + K$
 $K = 0.6 \text{ eV}$

KERTAS 2 / Paper 2

Bahagian A/Section A

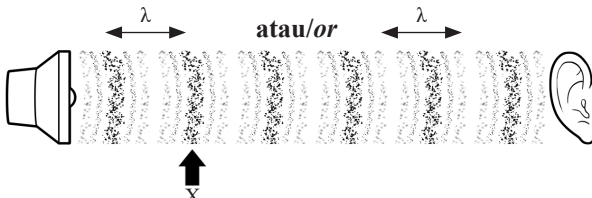
Soalan Questions		Jawapan Answers	Sub markah Subs marks	Jumlah markah Total marks
1	(a)	✓ – gelombang membujur <i>longitudinal wave</i>	1	4
	(b)	(i) Mampatan/ <i>Compression</i>	1	
		(ii)		
	(c)	Bertambah/ <i>Increases</i>	1	
2	(a)	Kuasa dua tempoh orbit sesuatu planet berkadar terus dengan kuasa tiga jejari orbitnya. <i>The square of the period of a planet is directly proportional to the cube of the radius of its orbit.</i>	1	2
	(b)	– Jejari orbit Bumi/ <i>Radius of orbit of Earth</i> – Tempoh orbit Bumi/ <i>Orbital period of Earth</i> – Tempoh orbit Zuhrah/ <i>Orbital period of Venus</i>	2	

Soalan Questions		Jawapan Answers	Sub markah Subs marks	Jumlah markah Total marks
	(c)	$\frac{T_1^2}{r_1^3} = \frac{T_2^2}{r_2^3}$ $\frac{1.00^2}{(1.50 \times 10^{11})^3} = \frac{0.20^2}{r_2^3}$ $r_2^3 = \frac{(1.50 \times 10^{11})^3 \times 0.20^2}{1.00^2}$ $r_2 = 5.13 \times 10^{10} \text{ m}$	2	5
3	(a)	Kuantiti/Jumlah haba yang diperlukan untuk menaikkan suhu 1 kg bahan sebanyak 1°C. <i>Amount of heat required to raise the temperature of 1 kg substance by 1°C.</i>	1	6
	(b)	(i) Muatan haba tentu cecair S lebih rendah daripada cecair R. <i>Specific heat capacity of liquid S is lower than liquid R.</i>	1	
		(ii) $Q = Pt$ $= (1\ 000)(8 \times 60)$ $= 480\ 000 \text{ J}$ $= 4.8 \times 10^5 \text{ J}$	2	
		(iii) $Q = mc\theta$ $480\ 000 = m(3\ 400)(75 - 25)$ $m = 2.82 \text{ kg}$	2	
4	(a)	(i) Diod/Diode	1	9
		(ii) Menyala/Lights up	1	
		(iii) Diod dipincang hadapan.//Lapisan susutan kecil. <i>Diode is forward biased.//Depletion layer is small.</i>	1	
	(b)	(i) Bertambah/Increases	1	
		(ii) Kecerunan/Gradient, k $= \frac{1.00 - 0.5}{0.8 - 0.6}$ $= \frac{0.5}{0.2}$ $= 2.4 \text{ AV}^{-1}$	2	
		(iii) Rintangan/Resistance, R $= \frac{1}{\text{Kecerunan/Gradient}}$ $= \frac{1}{2.4 \text{ AV}^{-1}}$ $= 0.42 \text{ VA}^{-1}$	2	
		(iv) I berkadar terus dengan V.//Kecerunan adalah malar.//Graf garis lurus bermula dari asalan. <i>I is directly proportional to V.//Gradient is constant.//The straight line graph passes through the origin.</i>	1	
5	(a)	Tolakan dan tarikan ke atas objek/ <i>Push and pull on an object</i>	1	
	(b)	(i) Kedudukan akhir peti kayu dalam Rajah 5(a) > Rajah 5(b). (atau sebaliknya) <i>The final position of the wooden crate in Diagram 5(a) > Diagram 5(b). (vice versa)</i>	1	
		(ii) Sudut daya dalam Rajah 5(a) < Rajah 5(b). (atau sebaliknya) <i>The angle of force in Diagram 5(a) < Diagram 5(b). (vice versa)</i>	1	

Soalan Questions		Jawapan Answers	Sub markah Subs marks	Jumlah markah Total marks
	(iii)	Pecutan peti kayu dalam Rajah 5(a) > Rajah 5(b). (atau sebaliknya) <i>The acceleration of the wooden crate in Diagram 5(a) > Diagram 5(b). (vice versa)</i>	1	9
(c)	(i)	Semakin berkurang sudut daya, semakin jauh kedudukan akhir peti kayu. (atau sebaliknya) <i>When the angle of force decreases, the final position of the wooden crate is further. (vice versa)</i>	1	
	(ii)	Semakin berkurang sudut daya, semakin bertambah pecutan peti kayu. (atau sebaliknya) <i>When the angle of force decreases, the acceleration of the wooden crate increases. (vice versa)</i>	1	
(d)		$F_{\text{net}} = ma$ $300 \cos / \cos 20^\circ - 120 = 70a$ $281.91 - 120 = 70a$ $a = 2.31 \text{ m s}^{-2}$	3	
6	(a)	Dua sumber gelombang yang mempunyai frekuensi yang sama dan sefasa/beza fasa yang sama. <i>Two sources of waves that have same frequency and in phase/constant phase difference.</i>	1	9
	(b)	(i) Jarak antara dua pembesar suara dalam Rajah 6(a) > Rajah 6(b). (atau sebaliknya) <i>The distance between the two loudspeakers in Diagram 6(a) > Diagram 6(b). (vice versa)</i>	1	
		(ii) Jarak antara dua bunyi kuat berturutan dalam Rajah 6(a) < Rajah 6(b). (atau sebaliknya) <i>The distance between two consecutive loud sounds in Diagram 6(a) < Diagram 6(b). (vice versa)</i>	1	
		(iii) Jarak gelombang bunyi dalam Rajah 6(a) = Rajah 6(b). (atau sebaliknya) <i>The wavelength of sound waves in Diagram 6(a) = Diagram 6(b). (vice versa)</i>	1	
	(c)	Semakin bertambah jarak antara dua pembesar suara, semakin berkurang jarak antara dua bunyi kuat berturutan. (atau sebaliknya) <i>When the distance between the two loudspeakers increases, the distance between two consecutive loud sounds decreases. (vice versa)</i>	1	
	(d)	Interferens/Interference	1	
	(e)	(i) – Bunyi kuat – Interferens membina//Puncak bertemu dengan puncak// Lembangan bertemu dengan lembangan <i>Loud sounds – Constructive interference//Crest meets crest//Trough meets trough</i> – Bunyi lemah – Interferens memusnah//Puncak bertemu dengan lembangan <i>Soft sounds – Destructive interference//Crest meets trough</i>	2	
		(ii) Berkurang/Decreases	1	
7	(a)	Pantulan/Reflection	1	

Soalan Questions		Jawapan Answers	Sub markah Subs marks	Jumlah markah Total marks	
(b)	(i)		2	9	
	(ii)	Maya//Tegak//Dibesarkan Virtual//Upright//Magnified (Mana-mana satu/Any one)	1		
	(c) (i)	Di titik fokus pemantul/At the focal point of the reflector Cahaya/Haba difokus/ditumpu. Light/Heat is focused/converged.	2		
	(ii)	Besar/Large Lebih banyak cahaya/haba dikumpul/dipantul. More light/heat is collected/reflected.	2		
(d)	Q		1		
8	(a)	Proses di mana nukleus yang tidak stabil menjadi lebih stabil dengan memancarkan sinaran radioaktif. A process in which an unstable nuclei becomes more stable by emitting radioactive radiation.	1	9	
	(b)	(i)	Cacat jisim/Mass defect: $m = 230.0331 - (226.0254 + 4.003)$ $= 4.7 \times 10^{-3}$ u.j.a./a.m.u. atau/or $= 7.802 \times 10^{-30}$ kg		2
		(ii)	Tenaga nuklear dibebaskan/Nuclear energy released: $E = mc^2$ $= (7.802 \times 10^{-30})(3 \times 10^8)^2$ $= 7.0218 \times 10^{-13}$ J		2
	(c)	(i)	Air berat/Heavy water Muatan haba tentu tinggi//Serap banyak haba High specific heat capacity//Absorb more heat		2
		(ii)	Rod boron/kadmium//Teras grafit/Boron/Cadmium rod//Graphite core Menyerap neutron yang berlebihan//Memperlahankan gerakan neutron Absorb excess neutrons//Slow down the neutrons		2

Bahagian B/Section B

Soalan Questions		Jawapan Answers	Sub markah Subs marks	Jumlah markah Total marks											
9	(a)	(i) Kuantiti jirim yang terkandung dalam sesuatu objek <i>Amount of matter in an object</i>	1												
		(ii) – Jisim kapal kargo adalah besar. <i>The mass of the cargo ship is large.</i> – Inersia kapal kargo adalah besar. <i>The inertia of the cargo ship is large.</i> – Apabila jisim bertambah, inersia bertambah. <i>When the mass increases, inertia increases.</i> – Kapal kargo susah dihentikan. <i>The cargo ship is difficult to be stopped.</i>	4												
	(b)	(i) $150 \text{ km j}^{-1}/\text{km h}^{-1}$ $= \frac{150 \times 1\,000 \text{ m}}{3\,600 \text{ s}}$ $= 41.67 \text{ m s}^{-1}$	5												
	(ii) $a = \frac{v - u}{t}$ $= \frac{41.67 - 0}{10 \times 60}$ $= 0.069 \text{ m s}^{-2}$														
	(iii) $s = (ut + \frac{1}{2} at^2) + vt$ $= [0 + \frac{1}{2} (0.069)(600)^2] + (150 \times 7\,200)$ $= 1.092 \times 10^6 \text{ m}$														
(c)	<table border="1"> <thead> <tr> <th>Ciri-ciri/Characteristics</th> <th>Sebab/Reason</th> </tr> </thead> <tbody> <tr> <td>M1: Bentuk kapal selam – Aerodinamik <i>Shape of submarine – Aerodynamic</i></td> <td>M2: Mengurangkan rintangan air <i>Reduce water resistance</i></td> </tr> <tr> <td>M3: Saiz tangki balast – Besar <i>Size of ballast tank – Large</i></td> <td>M4: Daya apungan besar <i>Large buoyant force</i></td> </tr> <tr> <td>M5: Jenis sumber tenaga – Nuklear <i>Type of energy sources – Nuclear</i></td> <td>M6: Hasilkan tenaga tinggi/Tahan lama <i>Produce high energy/Long lasting</i></td> </tr> <tr> <td>M7: Kadar pengoksidaan – Rendah <i>Rate of oxidation – Low</i></td> <td>M8: Tahan karat//Tidak karat//Tahan lama <i>Prevent rusting//Not rusty//Long lasting</i></td> </tr> <tr> <td>M9: Pilih K. <i>Choose K.</i></td> <td>M10: Kombinasi M1, M3, M5, M7 atau M2, M4, M6 dan M8. <i>Combination of M1, M3, M5, M7 or M2, M4, M6 and M8.</i></td> </tr> </tbody> </table>	Ciri-ciri/Characteristics	Sebab/Reason	M1: Bentuk kapal selam – Aerodinamik <i>Shape of submarine – Aerodynamic</i>	M2: Mengurangkan rintangan air <i>Reduce water resistance</i>	M3: Saiz tangki balast – Besar <i>Size of ballast tank – Large</i>	M4: Daya apungan besar <i>Large buoyant force</i>	M5: Jenis sumber tenaga – Nuklear <i>Type of energy sources – Nuclear</i>	M6: Hasilkan tenaga tinggi/Tahan lama <i>Produce high energy/Long lasting</i>	M7: Kadar pengoksidaan – Rendah <i>Rate of oxidation – Low</i>	M8: Tahan karat//Tidak karat//Tahan lama <i>Prevent rusting//Not rusty//Long lasting</i>	M9: Pilih K. <i>Choose K.</i>	M10: Kombinasi M1, M3, M5, M7 atau M2, M4, M6 dan M8. <i>Combination of M1, M3, M5, M7 or M2, M4, M6 and M8.</i>	10	20
Ciri-ciri/Characteristics	Sebab/Reason														
M1: Bentuk kapal selam – Aerodinamik <i>Shape of submarine – Aerodynamic</i>	M2: Mengurangkan rintangan air <i>Reduce water resistance</i>														
M3: Saiz tangki balast – Besar <i>Size of ballast tank – Large</i>	M4: Daya apungan besar <i>Large buoyant force</i>														
M5: Jenis sumber tenaga – Nuklear <i>Type of energy sources – Nuclear</i>	M6: Hasilkan tenaga tinggi/Tahan lama <i>Produce high energy/Long lasting</i>														
M7: Kadar pengoksidaan – Rendah <i>Rate of oxidation – Low</i>	M8: Tahan karat//Tidak karat//Tahan lama <i>Prevent rusting//Not rusty//Long lasting</i>														
M9: Pilih K. <i>Choose K.</i>	M10: Kombinasi M1, M3, M5, M7 atau M2, M4, M6 dan M8. <i>Combination of M1, M3, M5, M7 or M2, M4, M6 and M8.</i>														

Soalan Questions		Jawapan Answers	Sub markah Subs marks	Jumlah markah Total marks											
10	(a)	Suis automatik//Pembesar arus <i>Automatic switch//Current amplifier</i>	1												
	(b)	(i) – Ada bacaan pada mikroammeter, tiada bacaan pada miliammeter. <i>Microammeter shows a reading, milliammeter shows no reading.</i> – Tiada bacaan pada kedua-dua mikroammeter dan miliammeter. <i>Both microammeter and milliammeter show no reading.</i>	2												
		(ii) – Arus tapak, I_B mengalir.//Perubahan yang kecil pada arus tapak, I_B . <i>Base current, I_B flows.//Small change in base current, I_B.</i> – Arus pengumpul, I_C yang besar mengalir. <i>Large collector current, I_C flows.</i>	2												
	(c)	(i) Pembesaran arus/ <i>Current amplification:</i> $\beta = \frac{I_C}{I_B}$ $= \frac{5.7 \times 10^{-3}}{60 \times 10^{-6}}$ $= 95$	5												
		(ii) Arus pengeluar/ <i>Emitter current:</i> $I_E = I_B + I_C$ $= (60 \times 10^{-6}) + (5.7 \times 10^{-3})$ $= 5.76 \times 10^{-3} \text{ A}$													
(d)	<table border="1"> <thead> <tr> <th>Ciri-ciri/<i>Characteristics</i></th> <th>Sebab/<i>Reason</i></th> </tr> </thead> <tbody> <tr> <td>M1: Terminal JK – Termistor JK terminal – Thermistor</td> <td>M2: Peka terhadap haba//Apabila suhu tinggi, rintangan rendah <i>Sensitive to heat//When the temperature is high, resistance is low</i></td> </tr> <tr> <td>M3: Terminal LM – Perintang LM terminal – Resistor</td> <td>M4: Menghadkan I_B <i>To limit I_B</i></td> </tr> <tr> <td>M5: Terminal XY – Gegelung XY terminal – Coil</td> <td>M6: Melengkapkan litar kedua// Menambahkan voltan <i>Complete the secondary circuit// Increase the voltage</i></td> </tr> <tr> <td>M7: Terminal PQ – Sel 2 PQ terminal – Cell 2</td> <td>M8: Arus dapat mengalir dari pengumpul ke pengeluar pada transistor <i>Current is able to flow from the collector to the emitter in transistor</i></td> </tr> <tr> <td>M9: Pilih V <i>Choose V</i></td> <td>M10: Kombinasi M1, M3, M5, M7 atau M2, M4, M6 dan M8. <i>Combination of M1, M3, M5, M7 or M2, M4, M6 and M8.</i></td> </tr> </tbody> </table>	Ciri-ciri/ <i>Characteristics</i>	Sebab/ <i>Reason</i>	M1: Terminal JK – Termistor JK terminal – Thermistor	M2: Peka terhadap haba//Apabila suhu tinggi, rintangan rendah <i>Sensitive to heat//When the temperature is high, resistance is low</i>	M3: Terminal LM – Perintang LM terminal – Resistor	M4: Menghadkan I_B <i>To limit I_B</i>	M5: Terminal XY – Gegelung XY terminal – Coil	M6: Melengkapkan litar kedua// Menambahkan voltan <i>Complete the secondary circuit// Increase the voltage</i>	M7: Terminal PQ – Sel 2 PQ terminal – Cell 2	M8: Arus dapat mengalir dari pengumpul ke pengeluar pada transistor <i>Current is able to flow from the collector to the emitter in transistor</i>	M9: Pilih V <i>Choose V</i>	M10: Kombinasi M1, M3, M5, M7 atau M2, M4, M6 dan M8. <i>Combination of M1, M3, M5, M7 or M2, M4, M6 and M8.</i>	10	20
Ciri-ciri/ <i>Characteristics</i>	Sebab/ <i>Reason</i>														
M1: Terminal JK – Termistor JK terminal – Thermistor	M2: Peka terhadap haba//Apabila suhu tinggi, rintangan rendah <i>Sensitive to heat//When the temperature is high, resistance is low</i>														
M3: Terminal LM – Perintang LM terminal – Resistor	M4: Menghadkan I_B <i>To limit I_B</i>														
M5: Terminal XY – Gegelung XY terminal – Coil	M6: Melengkapkan litar kedua// Menambahkan voltan <i>Complete the secondary circuit// Increase the voltage</i>														
M7: Terminal PQ – Sel 2 PQ terminal – Cell 2	M8: Arus dapat mengalir dari pengumpul ke pengeluar pada transistor <i>Current is able to flow from the collector to the emitter in transistor</i>														
M9: Pilih V <i>Choose V</i>	M10: Kombinasi M1, M3, M5, M7 atau M2, M4, M6 dan M8. <i>Combination of M1, M3, M5, M7 or M2, M4, M6 and M8.</i>														

Bahagian C/Section C

Soalan Questions		Jawapan Answers	Sub markah Subs marks	Jumlah markah Total marks
11	(a)	(i) Aerofoil//Bentuk lurus//Aerofoil//Streamlined shape	1	
		(ii) <ul style="list-style-type: none"> – Halaju udara di bahagian atas sayap lebih tinggi. (atau sebaliknya) <i>The velocity of air above the wing is higher. (vice versa)</i> – Tekanan di bahagian bawah sayap lebih tinggi. (atau sebaliknya) <i>The pressure below the wing is higher. (vice versa)</i> – Perbezaan tekanan udara adalah besar. <i>The difference in pressure is large.</i> – Daya angkat terhasil.//Daya angkat = Perbezaan tekanan × Luas permukaan <i>Lift force is produced.//Lift force = Pressure difference × Area</i> (Mana-mana tiga/Any three) 	3	
	(b)	(i) <ul style="list-style-type: none"> – Sudut serang dalam Rajah 10.2(a) > Rajah 10.2(b). (atau sebaliknya) <i>The attack angle in Diagram 10.2(a) > Diagram 10.2(b). (vice versa)</i> – Jarak mendarat dalam Rajah 10.2(a) < Rajah 10.2(b). (atau sebaliknya) <i>The landing distance in Diagram 10.2(a) < Diagram 10.2(b). (vice versa)</i> – Ketinggian maksimum dalam Rajah 10.2(a) < Rajah 10.2(b). (atau sebaliknya) <i>The maximum height in Diagram 10.2(a) < Diagram 10.2(b). (vice versa)</i> – Apabila sudut serang bertambah, jarak mendarat berkurang. (atau sebaliknya) <i>When the attack angle increases, the landing distance decreases. (vice versa)</i> – Apabila ketinggian maksimum bertambah, jarak mendarat bertambah. (atau sebaliknya) <i>When the maximum height increases, the landing distance increases. (vice versa)</i> 	5	
		(ii) Prinsip Bernoulli/Bernoulli's Principle	1	

Soalan Questions		Jawapan Answers		Sub markah Subs marks	Jumlah markah Total marks
(c)	Pengubahsuaian/Modifications	Penerangan/Explanation		10	20
	M1: Permukaan papan luncur licin <i>The surface of surfing board is smooth</i>	M2: Untuk mengurangkan rintangan air <i>To reduce water resistance</i>			
	M3: Bentuk papan luncur aerodinamik <i>The shape of surfing board is aerodynamic</i>	M4: Untuk mengurangkan rintangan air <i>To reduce water resistance</i>			
	M5: Ketumpatan papan luncur rendah <i>The density of surfing board is small</i>	M6: Ringan//Jisim yang rendah <i>Light//Low mass</i>			
	M7: Bahan papan luncur komposit//gentian kaca <i>Material of surfing board is composite//fibre glass</i>	M8: Kuat//Tidak mudah patah <i>Strong//Does not break easily</i>			
	M9: Bahan layar kalis air <i>Material of sail is waterproof</i>	M10: Tidak serap air//Tidak basah <i>Does not absorb water//Does not get wet</i>			
	M11: Bahan layar kuat//nilon <i>Material of sail is strong//nylon</i>	M12: Tidak mudah koyak//Tahan lama <i>Does not tear easily//Long lasting</i>			
	M13: Ketumpatan layar rendah <i>Density of sail is low</i>	M14: Tidak mudah koyak//Tahan lama <i>Does not tear easily//Long lasting</i>			
	M15: Saiz layar besar <i>Size of sail is big</i>	M16: Daya besar untuk menentang angin/air <i>Large force to resist the wind/water</i>			

Kertas 1 / Paper 1

- 1 **C** Silinder penyukat digunakan untuk mengukur isi padu.
Measuring cylinder is used to measure volume.
- 2 **B** Jisim, laju, suhu dan masa adalah kuantiti skalar (mempunyai magnitud sahaja).
Mass, speed, temperature and time are scalar quantities (have magnitude only).
- 3 **D** Graf garis lurus dengan pintasan-y menunjukkan V (pemboleh ubah bergerak balas) bertambah secara linear dengan T (pemboleh ubah dimanipulasi).
Straight line graph with y-intercept shows V (responding variable) is increasing linearly with T (manipulated variable).
- 4 **C** Kedua-dua bola jatuh dengan pecutan graviti, $g = 9.81 \text{ m s}^{-2}$.
Both balls fall with gravitational acceleration, $g = 9.81 \text{ m s}^{-2}$.
- 5 **A** 0 – 5 s: Objek bergerak dengan halaju seragam.
Object moves with uniform velocity.
5 – 10 s: Objek pegun.
Objek is at rest.
- 6 **A**
$$m_1 u_1 + m_2 u_2 = (m_1 + m_2)v$$
$$(8\ 000)(20) + (1\ 000)(0) = (8\ 000 + 1\ 000)v$$
$$v = 17.78 \text{ m s}^{-1}$$
- 7 **C** Beg udara berfungsi untuk memanjangkan masa hentaman agar daya impuls dikurangkan.
Airbag is used to lengthen the time of impact hence reduce impulsive force.
- 8 **A**
$$F = \frac{mv^2}{R}$$
$$= \frac{(2)(5^2)}{2}$$
$$= 25 \text{ N}$$
- 9 **D** Halaju planet dalam sistem suria paling tinggi apabila paling hampir dengan Matahari.
Velocity of planet in the Solar System is the highest when it is closest to the Sun.
- 10 **B** Hukum Kepler Ketiga menyatakan bahawa kuasa dua tempoh orbit planet berkadar terus dengan kuasa tiga jejari orbit planet tersebut, $T^2 \propto r^3$.
Kepler's Third Law states that the square of the period of a planet is directly proportional to the cube of the radius of its orbit, $T^2 \propto r^3$.
- 11 **C** Termometer mengaplikasikan prinsip keseimbangan terma. Bacaan suhu termometer sama dengan suhu badan pesakit.
Thermometer applied heat equilibrium. Temperature reading of thermometer equal to the patient's body temperature.
- 12 **A** Daripada persamaan $\theta = \frac{Q}{mc}$, apabila haba dibekalkan dan jisim blok adalah sama, blok yang mempunyai muatan haba tentu paling rendah mengalami peningkatan suhu paling tinggi.
From equation $\theta = \frac{Q}{mc}$, when heat supplied and mass of blocks are equal, block with lowest specific high capacity will have a higher temperature rise.

13 B $Q_1 = Q_2$
 $m_1 c \theta_1 = m_2 c \theta_2$
 $(5)c(50) = (8)c(\theta_2)$
 $\theta_2 = 31.25^\circ\text{C}$

14 B Bagi gas berjisim dan bertekanan tetap, isi padu bertambah apabila suhu bertambah. Suhu bertambah kerana tenaga kinetik purata molekul bertambah apabila menerima haba daripada Matahari.
For a gas with fixed mass and pressure, the volume of the gas increases when its temperature increases. The increasing in temperature is due to the increasing of the average kinetic energy of the molecules when heat is supplied by the Sun.

15 A Semasa pelembapan, gelombang kehilangan tenaga maka amplitud gelombang berkurang.
Waves loss energy during damping causes the amplitude to decrease.

16 B $\frac{v_1}{\lambda_1} = \frac{v_2}{\lambda_2}$
 $\frac{v_1}{6} = \frac{18}{9}$
 $v_1 = 12 \text{ cm s}^{-1}$

17 D Corak interferens gelombang cahaya mempunyai jarak yang tetap antara pinggir cerah dan pinggir gelap.
Interference pattern of light waves have a uniform distance between bright and dark fringes.

18 D Sudut tuju ialah sudut di antara sinar tuju dan garis normal, manakala sudut biasan ialah sudut di antara sinar biasan dan garis normal.
Angle of incidence is the angle between the incident ray and the normal, whereas angle of refraction is the angle between refracted ray and the normal.

19 B Prisma dalam binokular mengaplikasikan pantulan dalam penuh apabila sinar cahaya melaluinya.
Prisms in binocular applies total internal reflection when light rays pass through them.

20 C Sinar cahaya yang melalui kanta cekung akan dibiaskan (mencapah) melalui titik fokus di hadapan kanta. Sinar cahaya yang melalui pusat optik kanta tidak mengalami pembiasan.
Light rays that pass through a concave lens will be refracted (diverged) from the focal point at the front of the lens. Light rays that pass through the optical centre does not experience refraction.

21 B Motosikal yang sedang memecut mempunyai daya bersih ke hadapan (arah pecutan).
A motorcycle which accelerates has a forward resultant/net force (in the direction of the acceleration).

22 C Daya mengufuk / Horizontal force;
 $F_x = 85 \cos 40^\circ$
 $= 65.11 \text{ N}$

23 C Guna kaedah segi tiga daya / Use triangle of forces method.

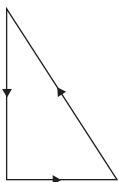

24 A Paras merkuri dalam turus yang disambungkan ke bekalan gas lebih rendah berbanding paras merkuri pada turus terbuka menunjukkan tekanan gas lebih tinggi (menekan merkuri ke bawah) berbanding atmosfera.
Mercury level in a column connected to the gas supply is lower compared to that in an open column shows that the gas pressure is higher (push the mercury downwards) compared to atmospheric pressure.

- 25 A $F_B = \rho Vg$
 $6 = (2\,400)(V)(9.81)$
 $V = 2.548 \times 10^{-4} \text{ m}^3$
- 26 B Angin yang ditiup di antara kedua-dua bola ping pong mempunyai halaju yang tinggi mewujudkan kawasan bertekanan rendah. Tekanan yang lebih tinggi masing-masing di kiri dan kanan bola ping pong menolak kedua-dua bola ping pong mendekati satu sama lain.
Blown air in between two ping pong balls have high velocity. This creates a low-pressure region. High pressure from the left and right of the ping pong balls respectively pushed the two ping pong balls towards each other.
- 27 C $Q = It$
 $= (0.45)(30 \times 60)$
 $= 810 \text{ C}$
- 28 B Dalam litar elektrik, ammeter disambungkan secara sesiri dengan konduktor, manakala voltmeter dipasang secara selari dengan konduktor.
In an electric circuit, ammeter is connected in series with a conductor, while voltmeter is connected in parallel with a conductor.
- 29 A Filamen bergelung mempunyai panjang yang tinggi, maka rintangan dalam filamen bertambah.
Coiled shape filament has a longer wire, this increase the resistance in the filament.
- 30 D $E = Pt$
 $= (2.0)(8)$
 $= 16 \text{ kWj / kWh}$
Unit elektrik (kWj) / Unit of electricity (kWh) = $16 \text{ kWj / kWh} \times 31 \text{ hari/days}$
 $= 496 \text{ kWj / kWh (496 unit/units)}$
Kos elektrik/Electric cost = $(200 \times \text{RM}0.22) + (296 \times \text{RM}0.26)$
 $= \text{RM}120.96$
- 31 A Guna peraturan Tangan Kiri Fleming untuk tentukan arah daya pada kedua-dua belah gegelung.
Use Fleming's Left-Hand rule to determine direction of forces acting on both coils.
- 32 D Tenaga elektrik dipindahkan pada voltan tinggi agar arus yang mengalir direndahkan, maka kehilangan kuasa semasa penghantaran berkurang. ($P = I^2R$)
Electrical energy transferred at higher voltage to reduce the current flow, hence reduce power loss during transmission. ($P = I^2R$)
- 33 C Sinar katod mempunyai cas negatif, bergerak dalam halaju tinggi, boleh dipesongkan oleh medan elektrik dan medan magnet serta mempunyai momentum dan tenaga kinetik yang ditukarkan kepada tenaga cahaya semasa menghentam skrin pendaflour.
Cathode rays is a negatively charge, travels at high velocity, deflected by electric and magnetic field, has momentum and kinetic energy which converts to light energy when it reaches the fluorescent screen.
- 34 B Elektron dan lohong menyeberangi lapisan susutan. Ini menyebabkan lapisan susutan berkurang, maka rintangan berkurang.
Electrons and holes drift to the opposite site. This will narrow the depletion layer thus reduce the resistance.
- 35 B Kapasitor berfungsi untuk menyimpan cas dan menjadi perata arus dalam litar rektifikasi.
Capacitor function to store charge and become a current smoother in a rectification circuit.
- 36 C Transistor digunakan sebagai suis untuk menghidupkan mentol secara automatik apabila keadaan sekeliling menjadi gelap.
Transistor is used as a switch to light up the bulb automatically when the surrounding become dark.

37 B Cacat jisim / *Mass defect*, m :
 $m = [2.01410 + 3.01605] - [4.00260 + 1.00867]$
 $= 0.01888$
 $= 0.01888 \times 1.66 \times 10^{-27}$
 $= 3.13408 \times 10^{-29} \text{ kg}$

Tenaga dibebaskan / *Energy released*, E :

$$E = mc^2$$
$$= (3.13408 \times 10^{-29})(3 \times 10^8)^2$$
$$= 2.820672 \times 10^{-12} \text{ J}$$

- 38 A** Rod kawalan dalam reaktor nuklear diperbuat daripada boron atau kadmium berfungsi untuk mengawal kadar tindak balas di dalam reaktor.
Control rods in a nuclear reactor made of boron or cadmium is used to control the rate of chain reaction inside the reactor.
- 39 C** Jasad hitam ialah suatu jasad unggul yang berupaya menyerap semua sinaran elektromagnet yang jatuh padanya.
A black body is an ideal body capable of absorbing all the electromagnetic radiation that falls on it.
- 40 C** Nilai pada pintasan pada paksi voltan menunjukkan voltan pengaktifan. (voltan terkecil yang melalui LED, di mana LED mengeluarkan cahaya)
The value on the intercept of the voltage axis shows activation voltage. (the smallest possible voltage across the LED just emits light)

Bahagian A/Section A

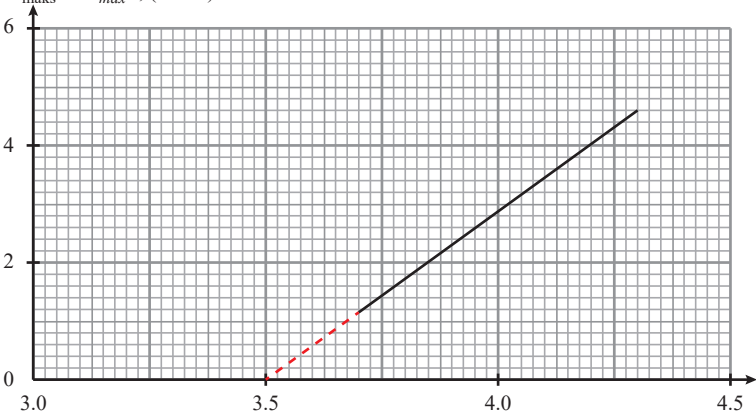
Soalan Questions		Jawapan Answers	Sub markah Subs marks	Jumlah markah Total marks
1	(a)	✓ – Gelombang melintang <i>Transverse wave</i>	1	4
	(b)	Air merambat dari kawasan dalam ke kawasan cetek // Laju gelombang air berkurang // Arah perambatan dibias mendekati garis normal <i>Water propagates from deep water region to shallow water region // The speed of water waves decreases // Direction of propagation refracted towards the normal</i>	1	
	(c)	Laju // Panjang gelombang. <i>Speed // Wavelength.</i>	1	
	(d)	Pembiasan gelombang / Pembiasan. <i>Refraction of wave / Refraction.</i>	1	
2	(a)	$\frac{F_1}{A_1} = \frac{F_2}{A_2}$ $\frac{25}{0.004} = \frac{F_2}{0.2}$ $F_2 = 1\,250\text{ N}$	1 1	5
	(b)	$\frac{A_2}{A_1} = \frac{1\,250}{25}$ = 50 kali ganda / 50 times	1 1	
	(c)	Takat didih tinggi // Kadar penyejatan rendah // Ketumpatan rendah. <i>High boiling point // Low evaporation rate // Low density.</i>	1	
3	(a)	Frekuensi minimum foton cahaya yang boleh menghasilkan kesan fotoelektrik pada satu jenis logam. <i>The minimum frequency of light photon required to produce photoelectric effect on a metal.</i>	1	1
	(b)	$K_{\text{maks}} / K_{\text{max}}, (10^{-20}\text{ J})$  Frekuensi ambang / <i>Threshold frequency, $f_0 = 3.5 \times 10^{14}\text{ Hz}$</i>	1 1	

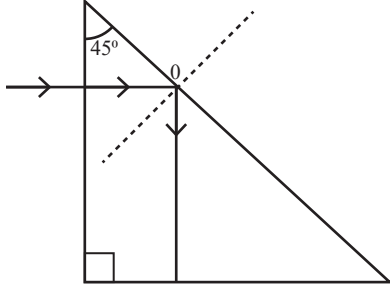
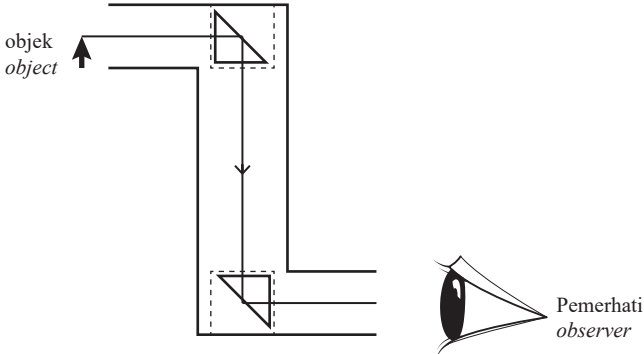
Soalan Questions		Jawapan Answers	Sub markah Subs marks	Jumlah markah Total marks
	(c)	Fungsi kerja/ <i>Work function</i> , $W = hf_0$ $= (6.63 \times 10^{-34}) (3.5 \times 10^{14})$ $= 2.3205 \times 10^{-19} \text{ J}$	1 1	6
	(d)	Bertambah. <i>Increase.</i>	1	
4	(a)	Sudut tuju dalam medium yang berketumpatan optik tinggi apabila sudut biasan dalam medium yang berketumpatan optik rendah sama dengan 90° . <i>The angle of incidence in the medium of high optical density when the angle of refraction in the medium of lower optical density is equals to 90°.</i>	1	9
	(b)	$n = \frac{1}{\sin c}$ $1.5 = \frac{1}{\sin c}$ $c = 41.8103^\circ$	1 1	
	(c) (i)	 <p>Lintasan betul / <i>Correct path</i> Anak panah sinar cahaya / <i>Arrow of light rays</i></p>	1 + 1	
	(ii)	Pantulan dalam penuh. <i>Total internal reflection.</i>	1	
	(d)	 <p>Kedudukan dua prisma yang betul. <i>Position of prisms is correct.</i></p> <p>Pantulan dalam penuh berlaku dua kali. <i>Total internal reflection occur twice.</i></p>	1 2	

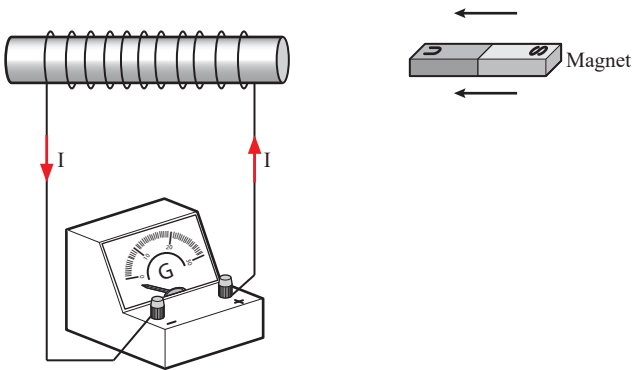
Soalan Questions		Jawapan Answers	Sub markah Subs marks	Jumlah markah Total marks	
5	(a)	Penghasilan d.g.e. aruhan merentasi suatu konduktor apabila terdapat gerakan relatif antara konduktor itu dengan suatu medan magnet atau apabila konduktor itu berada di dalam medan magnet yang berubah. <i>Production of an induced e.m.f. in a conductor when there is relative motion between the conductor and a magnetic field or when the conductor is in a changing magnetic field.</i>	1	9	
	(b)	Arus aruhan. <i>Induced current.</i>	1		
	(c)	(i)	Bilangan lilitan solenoid Rajah 5.1(a) > 5.2(b). <i>The number of turns of the solenoid Diagram 5.1(a) > 5.2(b).</i>		1
		(ii)	Kekuatan medan magnet Rajah 5.1(a) > 5.2(b). <i>The strength of magnetic field Diagram 5.1(a) > 5.2(b).</i>		1
		(iii)	Magnitud arus aruhan Rajah 5.1(a) > 5.2(b). <i>The magnitude of induced current Diagram 5.1(a) > 5.2(b).</i>		1
	(d)	(i)	Semakin bertambah bilangan lilitan solenoid, semakin bertambah kekuatan medan magnet. <i>The more the number of turns of the solenoid, the stronger the magnetic field.</i>		1
		(ii)	Semakin bertambah kekuatan medan magnet, semakin bertambah magnitud arus aruhan. <i>The increase of magnetic field, the increase of magnitude of induced current.</i>		1
	(e)	Hukum Faraday. <i>Faraday's Law.</i>	1		
	(f)		1		
	6	(a)	Daya per unit luas. <i>Force per unit area.</i>		1
(b)		✓ tekanan gas. <i>pressure of gas.</i>	1		
(c)		(i)	Isi padu udara dalam Rajah 6.1(b) < Isi padu udara dalam Rajah 6.1(a). <i>Air volume in Diagram 6.1(b) < Air volume in Diagram 6.1(a).</i>	1	
		(ii)	Tekanan udara dalam Rajah 6.1(b) > Tekanan udara dalam Rajah 6.1(a). <i>Air pressure in Diagram 6.1(b) > Air pressure in 6.1(a).</i>	1	
		(iii)	Bilangan zarah-zarah udara tidak berubah // Sama. <i>Number of air particles do not change // Same.</i>	1	
(d)		(i) Semakin bertambah isi padu udara dalam pam basikal, semakin berkurang tekanan udara yang dihasilkan. <i>The volume of air in bicycle pump increases, the pressure produced decreases.</i>	1		

Soalan Questions		Jawapan Answers	Sub markah Subs marks	Jumlah markah Total marks
	(ii)	Hukum Boyle. <i>Boyle's law.</i>	1	9
	(e)	$P_1 V_1 = P_2 V_2$ $(5)(200) = (25)(V_2)$ $V_2 = 40 \text{ cm}^3$	1 1	
7	(a)	Pemanjangan suatu spring adalah berkadar terus dengan daya yang bertindak ke atas spring jika tidak melebihi had kenyal spring itu. <i>The extension of a spring is directly proportional to the force applied on the spring provided the elastic limit of the spring is not exceeded.</i>	1	
	(b)	<p>Daya / N Force</p> <p>Pemanjangan / cm Extension</p>	1	
	(c)	(i) – Tinggi / High. – Mampu menahan daya tinggi / Withstand high force.	1 1	9
		(ii) – Kecil // Rendah / Small // Low. – Ringan // Jisim kecil. / Light // Small mass.	1 1	
		(iii) – Tinggi / High. – Boleh kembali ke bentuk asal setelah daya tinggi yang dikenakan ke atas spring dialihkan. <i>Able to return to initial shape and size after the force acting is removed.</i>	1 1	
		(iv) R	1	
8	(a)	Pengering rambut menggunakan/melesapkan 1 100 J tenaga elektrik dalam satu saat apabila dibekalkan voltan sebanyak 240 V. <i>The hairdryer use/dissipated 1 100 J of electrical energy in one second when a voltage of 240 V is supplied.</i>	1	
	(b)	$R = \frac{\rho l}{A}$ $= \frac{(1.1 \times 10^{-6})(2)}{5 \times 10^{-9}}$ $= 440 \Omega$	1 1	

Soalan Questions		Jawapan Answers	Sub markah Subs marks	Jumlah markah Total marks	
(c)	(i)	Bahan elemen pemanas – Nikrom // Rintangan tinggi <i>Type of heating element – Nichrome // High resistance</i> Sebab – Rintangan tinggi // Banyak haba dihasilkan <i>Reason – High resistance // Produced more heat energy</i>	1 1	9	
	(ii)	Ketebalan dawai elemen pemanas – Kecil // Nipis <i>Thickness of the heating element – Small // Thin</i> Sebab – Rintangan tinggi // Banyak haba dihasilkan <i>Reason – High resistance // Produced more heat energy</i>	1 1		
	(iii)	Kuasa kipas yang digunakan – Tinggi // Besar <i>Power of the fan – High // Great // Big</i> Sebab – Banyak udara panas ditiup <i>Reason – Blow more hot air</i>	1 1		
9	(a)	(i)	Tenaga keupayaan graviti bermaksud tenaga yang diperolehi oleh suatu objek disebabkan kedudukannya dari pusat Bumi. <i>Gravitational potential energy is the energy gained by an object due to its position from the centre of the Earth.</i>	1	
		(ii)	$u = -\frac{GMm}{r}$ $u = -\frac{(6.67 \times 10^{-11})(5.97 \times 10^{24})(300)}{(6.37 \times 10^6) + (3 \times 10^5)}$ $= -1.79 \times 10^{10} \text{ J (dengan unit / with unit)}$	1 1	
		(iii)	$T = \sqrt{\frac{4\pi^2 r^3}{GM}}$ $(86\,400)^2 = \frac{4\pi^2 r^3}{(6.67 \times 10^{-11})(5.97 \times 10^{24})}$ $r = 4.22 \times 10^7 \text{ m (dengan unit / with unit)}$	1 + 1 1	
	(b)	– Arah gerakan satelit sama dengan arah putaran Bumi. <i>Direction of satellite motion same as the direction of Earth rotation.</i> – Tempoh putaran orbit adalah 24 jam. <i>Orbital period is 24 hours.</i> – Berada di atas kedudukan geografi yang sama di permukaan Bumi. <i>Located at the same geographical location on Earth surface.</i> – Sesuai digunakan sebagai satelit komunikasi. <i>Suitable to be use as communication satellite.</i>	1 1 1 1		

Soalan Questions		Jawapan Answers	Sub markah Subs marks	Jumlah markah Total marks
(c)	Cadangan/Suggestion	Sebab/Reason		
	Jenis satelit geopegun. <i>Type of satellite geostationary.</i>	Kedudukan geografi satelit di permukaan Bumi pada lokasi tetap. <i>Geographical position of satellite above Earth at fixed location.</i>	1 + 1	
	Tempoh orbit 24 jam. <i>Orbital period 24 hours.</i>	Sama dengan tempoh putaran lengkap Bumi. <i>Same with the complete period of rotation of Earth.</i>	1 + 1	
	Arah edaran dari Barat ke Timur. <i>Direction of orbit from West to East.</i>	Arah putaran sama dengan arah putaran Bumi. <i>The direction of rotation is the same as the direction of rotation of the Earth.</i>	1 + 1	
	Bilangan satelit 3. <i>Number of satellites 3.</i>	Memastikan gelombang penyiaran sampai ke seluruh dunia. <i>Ensure the broadcast reaches the whole world.</i>	1 + 1	
	Satelit X. <i>Satellite X.</i>	Kedudukan geografi satelit di permukaan Bumi pada lokasi tetap, tempoh orbit 24 jam, arah edaran Barat ke Timur, bilangan satelit 3. <i>Geographical position of satellite above Earth at fixed location, orbital period 24 hours, direction of orbit from West to East, number of satellites 3.</i>	1 + 1	
10	(a)	Pelakuran nuklear. <i>Nuclear fusion.</i>	1	
	(b)	– Satu nukleus yang lebih besar, helium, terbentuk dan satu neutron dibebaskan. <i>One larger nucleus, helium is formed, and a neutron is released.</i> – Susutan jisim diubah menjadi tenaga yang dibebaskan. <i>Some mass (mass defect) is converted into energy and released.</i> ${}^2_1\text{H} + {}^3_1\text{H} \rightarrow {}^4_2\text{He} + {}^1_0\text{n} + \text{tenaga/energy}$	1 1 2	
	(c)	Susutan jisim / <i>Mass defect</i> , $m = [2.014102 + 3.016050] - [4.002603 + 1.008665]$ $= 0.018884 \text{ u.j.a / a.m.u}$ $= 0.018884 \times 1.66 \times 10^{-27} \text{ kg}$ $= 3.134744 \times 10^{-29} \text{ kg}$ $E = mc^2$ $= (3.134744 \times 10^{-29})(3 \times 10^8)^2$ $= 2.8212696 \times 10^{-12} \text{ J}$	1 1 1 1 1	
				20

Soalan Questions		Jawapan Answers	Sub markah Subs marks	Jumlah markah Total marks												
(d)		<table border="1"> <thead> <tr> <th>Ciri-ciri/Characteristics</th> <th>Sebab/Reason</th> </tr> </thead> <tbody> <tr> <td>Bahan api reaktor nuklear: Uranium-235 <i>The fuel of the nuclear reactor: Uranium-235</i></td> <td>Nukleus yang lebih tidak stabil. <i>More unstable nucleus.</i></td> </tr> <tr> <td>Separuh hayat bahan api: Panjang <i>Half-life of fuel: Long</i></td> <td>Ia dapat digunakan untuk jangka masa panjang. <i>It can be used for a long time.</i></td> </tr> <tr> <td>Tindak balas kimia bagi penghasilan gas pernafasan: Elektrolisis air <i>A chemical reaction to produce gas for breathing: Water electrolysis</i></td> <td>Gas oksigen untuk pernafasan dapat dihasilkan. <i>Oxygen gas for respiration can be produced.</i></td> </tr> <tr> <td>Perisai reaktor nuklear: Konkrit <i>Shield of nuclear reactor: Concrete</i></td> <td>Menghalang kebocoran sinaran radioaktif dari teras ke reaktor. <i>Prevents leakage of radioactive radiation from the reactor core.</i></td> </tr> <tr> <td>Pilih J. <i>Choose J.</i></td> <td>Bahan api adalah uranium-235, Separuh hayat yang panjang, tindak balas kimia elektrolisis air dan perisai konkrit. <i>Because of the uranium-235 fuel, long half-life, water electrolysis chemical reaction and concrete shield.</i></td> </tr> </tbody> </table>	Ciri-ciri/Characteristics	Sebab/Reason	Bahan api reaktor nuklear: Uranium-235 <i>The fuel of the nuclear reactor: Uranium-235</i>	Nukleus yang lebih tidak stabil. <i>More unstable nucleus.</i>	Separuh hayat bahan api: Panjang <i>Half-life of fuel: Long</i>	Ia dapat digunakan untuk jangka masa panjang. <i>It can be used for a long time.</i>	Tindak balas kimia bagi penghasilan gas pernafasan: Elektrolisis air <i>A chemical reaction to produce gas for breathing: Water electrolysis</i>	Gas oksigen untuk pernafasan dapat dihasilkan. <i>Oxygen gas for respiration can be produced.</i>	Perisai reaktor nuklear: Konkrit <i>Shield of nuclear reactor: Concrete</i>	Menghalang kebocoran sinaran radioaktif dari teras ke reaktor. <i>Prevents leakage of radioactive radiation from the reactor core.</i>	Pilih J. <i>Choose J.</i>	Bahan api adalah uranium-235, Separuh hayat yang panjang, tindak balas kimia elektrolisis air dan perisai konkrit. <i>Because of the uranium-235 fuel, long half-life, water electrolysis chemical reaction and concrete shield.</i>	1 + 1	20
	Ciri-ciri/Characteristics	Sebab/Reason														
	Bahan api reaktor nuklear: Uranium-235 <i>The fuel of the nuclear reactor: Uranium-235</i>	Nukleus yang lebih tidak stabil. <i>More unstable nucleus.</i>														
	Separuh hayat bahan api: Panjang <i>Half-life of fuel: Long</i>	Ia dapat digunakan untuk jangka masa panjang. <i>It can be used for a long time.</i>														
	Tindak balas kimia bagi penghasilan gas pernafasan: Elektrolisis air <i>A chemical reaction to produce gas for breathing: Water electrolysis</i>	Gas oksigen untuk pernafasan dapat dihasilkan. <i>Oxygen gas for respiration can be produced.</i>														
	Perisai reaktor nuklear: Konkrit <i>Shield of nuclear reactor: Concrete</i>	Menghalang kebocoran sinaran radioaktif dari teras ke reaktor. <i>Prevents leakage of radioactive radiation from the reactor core.</i>														
Pilih J. <i>Choose J.</i>	Bahan api adalah uranium-235, Separuh hayat yang panjang, tindak balas kimia elektrolisis air dan perisai konkrit. <i>Because of the uranium-235 fuel, long half-life, water electrolysis chemical reaction and concrete shield.</i>															
		1 + 1														
		1 + 1														
		1 + 1														
		1 + 1														
		1 + 1														
11	(a)	npn	1													
	(b)	– Pada hari panas, rintangan termistor rendah, maka voltan termistor rendah. <i>In a hot day, resistance of thermistor is low, voltage of thermistor is low.</i>	1													
		– Voltan tapak tinggi, maka arus tapak yang kecil mengalir. <i>Base voltage is high, low base current flow.</i>	1													
		– Transistor dihidupkan. <i>Transistor is switched on.</i>	1													
		– Arus pengumpul yang besar mengalir, maka kipas dihidupkan. <i>Collector current flows, fan is switched on.</i>	1													
	(c)	– Apabila rintangan termistor rendah, voltan merentasi termistor juga berkurang. <i>When the resistance of the thermistor is low, the voltage across it decreases.</i>	1													
		– Apabila rintangan termistor tinggi, voltan merentasi termistor akan meningkat. <i>When the resistance of the thermistor is high, the voltage across it increases.</i>	1													
		– Berdasarkan konsep litar pembahagi voltan, apabila voltan merentasi termistor berkurang, voltan merentasi perintang R akan meningkat. <i>Based on the potential divider concept when the voltage across the thermistor decreases, the voltage across the resistor R increases</i>	1													

Soalan Questions		Jawapan Answers	Sub markah Subs marks	Jumlah markah Total marks												
		<p>– Apabila voltan merentasi perintang R melebihi voltan minimum merentasi tapak, arus tapak, I akan mengalir dan transistor dapat dihidupkan. <i>When the voltage across the resistor R exceeds the minimum voltage across the base, the base current, I will flow, and the transistor will be turn on.</i></p> <p>– Maka, nilai rintangan termistor yang rendah dan nilai rintangan perintang R yang tinggi adalah syarat untuk menghidupkan kipas. <i>Thus, a low thermistor resistance value and a high resistor R resistance value is a condition to turn on the fan.</i></p>	1 1													
(d)		<table border="1"> <thead> <tr> <th>Modifikasi/Modification</th> <th>Penerangan/Explanation</th> </tr> </thead> <tbody> <tr> <td>Komponen P diganti dengan termistor. <i>Component P is replaced with thermistor.</i></td> <td>Untuk mengesan haba apabila suhu tinggi. <i>To detect heat when temperature is high.</i></td> </tr> <tr> <td>Tambah perintang tapak. <i>Add a base resistor.</i></td> <td>Untuk menghadkan arus tapak. <i>To limit the base current.</i></td> </tr> <tr> <td>Mentol diganti dengan suis geganti. <i>Bulb replaced with relay switch.</i></td> <td>Untuk menghidupkan litar sekunder. <i>To switch on the secondary circuit.</i></td> </tr> <tr> <td>Tambah motor dalam litar sekunder. <i>Add motor in secondary circuit.</i></td> <td>Untuk menghidupkan penyiram air. <i>To switch on the water sprinkler.</i></td> </tr> <tr> <td>Guna 240 V dalam litar sekunder. <i>Use 240 V in secondary circuit.</i></td> <td>Untuk menghidupkan motor. <i>To switch on the motor.</i></td> </tr> </tbody> </table>	Modifikasi/Modification	Penerangan/Explanation	Komponen P diganti dengan termistor. <i>Component P is replaced with thermistor.</i>	Untuk mengesan haba apabila suhu tinggi. <i>To detect heat when temperature is high.</i>	Tambah perintang tapak. <i>Add a base resistor.</i>	Untuk menghadkan arus tapak. <i>To limit the base current.</i>	Mentol diganti dengan suis geganti. <i>Bulb replaced with relay switch.</i>	Untuk menghidupkan litar sekunder. <i>To switch on the secondary circuit.</i>	Tambah motor dalam litar sekunder. <i>Add motor in secondary circuit.</i>	Untuk menghidupkan penyiram air. <i>To switch on the water sprinkler.</i>	Guna 240 V dalam litar sekunder. <i>Use 240 V in secondary circuit.</i>	Untuk menghidupkan motor. <i>To switch on the motor.</i>	1 + 1 1 + 1 1 + 1 1 + 1 1 + 1	20
Modifikasi/Modification	Penerangan/Explanation															
Komponen P diganti dengan termistor. <i>Component P is replaced with thermistor.</i>	Untuk mengesan haba apabila suhu tinggi. <i>To detect heat when temperature is high.</i>															
Tambah perintang tapak. <i>Add a base resistor.</i>	Untuk menghadkan arus tapak. <i>To limit the base current.</i>															
Mentol diganti dengan suis geganti. <i>Bulb replaced with relay switch.</i>	Untuk menghidupkan litar sekunder. <i>To switch on the secondary circuit.</i>															
Tambah motor dalam litar sekunder. <i>Add motor in secondary circuit.</i>	Untuk menghidupkan penyiram air. <i>To switch on the water sprinkler.</i>															
Guna 240 V dalam litar sekunder. <i>Use 240 V in secondary circuit.</i>	Untuk menghidupkan motor. <i>To switch on the motor.</i>															

Kertas 1 / Paper 1

- 1 **D** Daya ialah kuantiti vektor. Daya mempunyai arah dan magnitud yang tersendiri. Tenaga dan kuasa mempunyai magnitud tetapi tidak mempunyai hala tuju. Tekanan mempunyai magnitud tetapi tidak mempunyai arah tertentu. Tekanan atmosfera bertindak dalam semua arah.
Force is a vector quantity. Force has its own direction and magnitude. Energy and power have magnitude but do not have direction. Pressure has magnitude but does not have a particular direction. Atmospheric pressure acts in all directions.
- 2 **C** Pemboleh ubah bergerak balas merujuk kepada paksi-y
 Berkadar terus kerana garis lurus melalui origin
Responding variable refer to y-axis of graph
Directly proportional because the straight-line pass-through origin
- 3 **C** Jarak = Luas trapezium + Luas segitiga
Distance = Area of trapezium + Area of triangle

$$= \left[\frac{1}{2} \times (20 + 12) \times 8 \right] + \left[\frac{1}{2} \times 4 \times 8 \right]$$

$$= 144 \text{ m}$$
- 4 **A** Inersia ialah kecenderungan sesuatu objek untuk kekal pada keadaan asalnya.
Inertia is the tendency of an object to remain at its original situation.
- 5 **B** Kedua-dua objek bergabung dan bergerak bersama-sama dengan halaju sepunya selepas perlanggaran mengalami perlanggaran tak kenyal. Momentum kereta diabadikan, tenaga kinetik tidak diabadikan dan jumlah tenaga diabadikan.
The two objects combine and move together with a common velocity after the collision experience inelastic collision. Their momentum is conserved, kinetic energy is not conserved and total energy is conserved.
- 6 **A** Menurut Hukum Kepler Kedua: Planet bergerak lebih cepat apabila ia lebih dekat dengan Matahari dan bergerak lebih perlahan apabila ia jauh dari Matahari.
According to Kepler Second Law: Planet moves faster when it is closer to the Sun and moves slower when it is further from the Sun.
- 7 **C** $F = \frac{Gm_1m_2}{r^2} \rightarrow F \propto \frac{1}{r^2}$
 Daya graviti, F berkadar songsang dengan jarak satelit, r
 Nilai r lebih rendah, nilai F lebih tinggi
Force of gravity, F is inversely proportional to distance of satellite, r
A lower value of r, the higher value of F
- $g = \frac{GM}{r^2} \rightarrow g \propto \frac{1}{r^2}$
 Pecutan graviti, g berkadar songsang dengan jarak satelit, r
 Nilai r yang lebih rendah, nilai g lebih tinggi
Gravitational acceleration, g is inversely proportional to distance of satellite, r
A lower value of r, the higher value of g
- 8 **B** Anggarkan M = jisim Bumi, R = jejari Bumi, v_x = halaju lepas planet X
 Diberi jisim planet X = 400M, jejari planet X = 10R
Assume M = mass of Earth, R = radius of Earth, v_x = escape velocity of planet X
Given mass of planet X = 400M, radius of planet X = 10R

$$v = \sqrt{\frac{2GM}{R}}$$

$$11.2 = \sqrt{\frac{2GM}{R}} \dots\dots\dots(1)$$

$$v_x = \sqrt{\frac{2G(400M)}{10R}}$$

$$= \sqrt{\frac{80GM}{R}} \dots\dots\dots(2)$$

(1) ÷ (2) :

$$\frac{v_x}{11.2} = \frac{\sqrt{\frac{80GM}{R}}}{\sqrt{\frac{2GM}{R}}}$$

$$\frac{v_x}{11.2} = \sqrt{\frac{80GM}{R} \times \frac{R}{2GM}}$$

$$V_x = 11.2 \times \sqrt{40}$$

$$= 70.84 \text{ ms}^{-1}$$

- 9 A Konduktor haba yang baik akan memberi peningkatan suhu yang paling tinggi pada masa, jisim dan bekalan kuasa yang sama.

A good heat conductor will give the highest temperature rise for the same time, mass and power supply.

$$Pt = mc\theta$$

$$\theta = \frac{Pt}{mc}$$

$$\theta \propto \frac{1}{c}$$

Peningkatan suhu, berkadar songsang dengan c. Nilai c yang kecil akan menghasilkan peningkatan suhu yang lebih tinggi iaitu sifat konduktor haba yang terbaik.

The increase in temperature, θ is inversely proportional to c. A small value of c will result in a higher temperature increase which is the characteristic of the best heat conductor.

- 10 B Pada suhu mutlak 0 K (= -273 °C), molekul gas tidak bergerak dan tenaga kinetiknya adalah sifar.
At the absolute temperature of 0 K (= -273 °C), gas molecules are not moving and their kinetic energy is zero.

11 B
$$\theta = \frac{l_\theta - l_0}{l_{100} - l_0} \times 100$$

$$40 = \frac{l_\theta - 1.0}{28.0 - 1.0} \times 100$$

$$l_\theta = 11.8 \text{ cm}$$

- 12 C Daya paduan untuk OX dan OY ialah pepenjuru segi empat selari dari titik O
Resultant force of OX and OY is the diagonal of parallelogram from point O

- 13 D Anggapkan pemanjangan satu spring = x, bilangan spring = n
Assume the extension of one spring = x, number of spring = n

Jumlah pemanjangan spring yang disusun secara siri = nx

Total extension of spring arranged in series = nx

Jumlah pemanjangan spring secara selari = $\frac{n}{x}$

Total extension of spring arranged in parallel = $\frac{n}{x}$

Jumlah pemanjangan susunan spring X = $\frac{x}{4} + \frac{x}{2} = \frac{3}{4}x$

Total extension of the spring arrangement X = $\frac{x}{4} + \frac{x}{2} = \frac{3}{4}x$

Jumlah pemanjangan susunan spring Y = $\frac{x}{3}$

Total extension of the spring arrangement Y = $\frac{x}{3}$

Jumlah pemanjangan susunan spring Z = $\frac{x}{2} + x = \frac{3}{2}x$

Total extension of the spring arrangement Z = $\frac{x}{2} + x = \frac{3}{2}x$

Z > X > Y

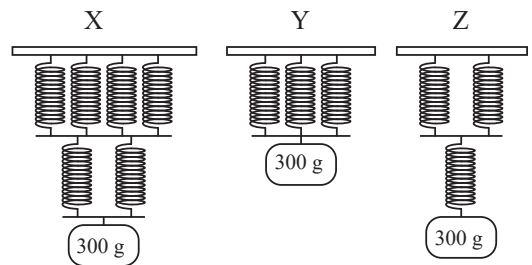

- 14 C** Pecutan graviti sama di semua lokasi atas Bumi
Acceleration gravity are same at every location on Earth
 Tenaga kinetik = $\frac{1}{2}mv^2$, Tenaga keupayaan graviti = mgh
 m tidak sama, tenaga kinetik, tenaga keupayaan graviti, halaju tidak sama
Kinetic energy = $\frac{1}{2}mv^2$, Gravitational potential energy = mgh
m different, kinetic energy, gravitational potential energy, velocity different
- 15 A** $F = ma$
 $(2000)(9.81) \sin 12^\circ - 500 = (2000)(a)$
 $a = 1.79 \text{ ms}^{-2}$
- 16 B** Pembelauan gelombang ialah fenomena di mana gelombang tersebar semasa ia melalui celah atau di sekeliling halangan kecil.
Diffraction of waves is a phenomenon in which waves spread out as they pass through a gap or round a small obstacle.
 Pulau di Rajah 13 merupakan halangan kecil.
Island in Diagram 13 represent a small obstacle.
- 17 C** Kesan pembiasan dari kawasan air dalam ke kawasan air cetek: Kelajuan gelombang berkurang dan panjang gelombang berkurang.
Effects of refraction from deep water region to shallow water region: Wave speed decreases and wavelength of wave decreases.
- 18 B** Dalam spektrum elektromagnet, gelombang disusun daripada tenaga rendah kepada tenaga tinggi (atau sebaliknya). Penghujung tenaga tinggi yang bermula dengan sinar gama diikuti oleh sinar-X, sinar ultraungu, sinar inframerah, gelombang mikro dan berakhir dengan gelombang radio.
In the electromagnetic spectrum, waves are arranged from low energy to high energy (or vice versa). The high energy end which starts with gamma rays is followed by X-ray, ultraviolet ray, infrared ray, microwave and ends with radio wave.
- 19 D** Diberi /Given, $f = 15 \text{ cm}$, $u = 20 \text{ cm}$

$$\frac{1}{f} = \frac{1}{u} + \frac{1}{v}$$

$$\frac{1}{15} = \frac{1}{20} + \frac{1}{v}$$
 $v = 60 \text{ cm}$
- 20 B** A Kanta objektif dan kanta mata adalah kanta cembung
A The objective lens and eyepiece lens are convex lens
 C / D Pelarasan normal = jarak fokus kanta mata + jarak fokus kanta objektif
C / D Normal adjustment = focal length of eyepiece + focal length of objective lens
- 21 A** Rajah 17 menunjukkan seorang lelaki berdiri dekat dengan cermin cekung di mana jarak objek kurang daripada panjang fokus cermin cekung (ciri-ciri imej yang terbentuk: maya, tegak dan membesar).
Diagram 17 shows a man stands near to a concave mirror with the object distance less than its focal length (image characteristic formed: virtual, upright and magnified)
- 22 A** Tekanan atmosfera bertindak pada permukaan laut dan adalah malar di setiap titik atas permukaan laut.
 Tekanan air = ρhg (tekanan air berkadar kedalaman air), kedalaman ketam > ikan
Atmospheric pressure acts on the sea surface and is constant at every point above the sea surface.
Water pressure = ρhg (water pressure directly proportional to water depth), depth of crab > fish

- 23 B** Prinsip Bernoulli menyatakan bahawa tekanan bendalir yang bergerak berkurangan apabila halaju bendalir bertambah dan begitu juga sebaliknya.
 Kelajuan aliran udara pada $X > Y$, tekanan pada $X < Y$.
Bernoulli's principle states that the pressure of a moving fluid decreases as the velocity of the fluid increases and vice versa.
Speed of air flow at $X > Y$, pressure at $X < Y$.
- 24 B** Daya apungan / *Buoyant force*,
 $F_B = \rho Vg$
 $= (1.184 \times 500 \times 9.81) = 5\,807.52\text{ N}$
 Berat / *Weight*,
 $W = mg$
 $= 250 \times 9.81 = 2\,452.5\text{ N}$
 Daya paduan / *Resultant force*
 $= 5\,807.52 - 2\,452.5$
 $= 3\,355.02\text{ N}$
- 25 C** Frekuensi ayunan bola polistirena bertambah menunjukkan kekuatan medan elektrik bertambah.
 $E = \frac{V}{d}$
 E = kekuatan medan elektrik, V = beza keupayaan antara dua plat yang selari, d = jarak antara dua plat selari. E berkadar terus dengan V dan berkadar songsang dengan d . E meningkat apabila V meningkat atau d berkurang
The frequency of oscillation of the polystyrene ball increases indicating the strength of the electric field increases.
 $E = \frac{V}{d}$
 E = electric field strength, V = potential difference between two parallel plates, d = distance between two parallel plates.
E is directly proportional to V and inversely proportional to d. E increases as V increases or d decreases.
- 26 A** Anggap R = perintang mentol
Assume R = resistance of bulb
 $V = IR$
 $9 = (1.5)(5 + R)$
 $R = 1\ \Omega$
 Jumlah rintangan untuk perintang $5\ \Omega$ and $10\ \Omega$, R_p
Total resistance of resistor $5\ \Omega$ and $10\ \Omega$, R_p
 $\frac{1}{R_p} = \frac{1}{5} + \frac{1}{10}$
 $R_p = 3.33\ \Omega$
 $R_T = R_p + R$
 $= 4.33\ \Omega$
 $V = IR$
 $9 = I(4.33)$
 $I = 2.08\text{ A}$
- 27 B** Gelombang bunyi adalah gelombang mekanikal kerana ia memerlukan medium untuk memindahkan tenaga dari satu titik ke titik yang lain. Gelombang bunyi ialah gelombang membujur kerana zarah medium bergetar pada arah yang selari dengan arah perambatan gelombang.
Sound wave is mechanical wave because it required medium to transfer energy from one point to another. Sound wave is longitudinal wave because particles of the medium vibrate in the direction to the direction of propagation of the wave.
- 28 C** $E = V + Ir$
 $V = -(r)I + E$
 $y = mx + c$
 E (D.g.e/ *E.m.f*) = pintasan- V / V -intercept
 r = kecerunan graf/ *Gradient of graph*

29 D

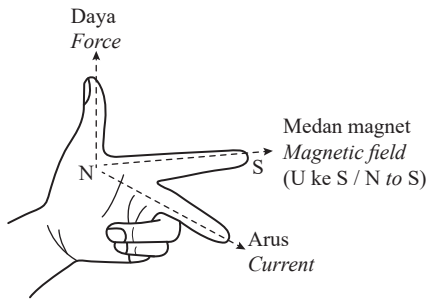

Guna petua tangan kiri Fleming untuk menentukan arah daya
Use Fleming's left-hand rule to determine the direction of force

30 D Ammeter mengukur arus dalam gegelung primer, I_p .

Ammeter measure current in the primer coil, I_p .

Dalam sebuah transformer unggul,

In an ideal transformer,

$$P_{in} = P_{out}$$

$$(240)I_p = (5)(1.5)$$

$$V_s I_s = 7.5$$

$$(5)I_s = 7.5$$

$$I_s = 1.5 \text{ A}$$

$$I_p = \frac{7.5}{240}$$

$$= 0.031 \text{ A}$$

$$= 0.031 \times 1000$$

$$= 31 \text{ mA}$$

31 D D.g.e teraruh solenoid bertambah apabila kelajuan gerakan relatif bertambah, bilangan lilitan solenoid bertambah dan kekuatan medan magnet bertambah. Apabila magnet dilepaskan dari kedudukan yang lebih rendah, magnet bergerak lebih perlahan. Kadar pemotongan medan magnet dikurangkan. Arus dihasilkan berkurang.

The induced e.m.f. of a solenoid increases when the speed of relative motion increases, the number of turns of the solenoid increases and the strength of the magnetic field increases. When the magnet is released from a lower position, the magnet moves slower. The rate of cutting of the magnetic field is reduce. Less current is produced.

32 D Arus dapat mengalir melalui diod atas yang disambungkan pincang ke hadapan kepada bekalan kuasa tetapi arus dihentikan oleh diod bawah yang disambungkan dalam pincang songsang kepada bekalan kuasa.

Current able to flow through the upper diode which is connected forward bias to power supply but current in stopped by lower diode which is connected in reversed bias to power supply.

33 C $\frac{1}{2} mv^2 = eV$

$$\frac{1}{2} (9 \times 10^{-31}) v^2 = (1.6 \times 10^{-19})(5000)$$

$$v = 4.22 \times 10^7 \text{ ms}^{-1}$$

34 A Dalam separuh kitaran positif, diod Q dan R dipincang ke hadapan manakala P dan S dipincang terbalik. Dalam separuh kitaran negatif, diod P dan S dipincang ke hadapan manakala Q dan R dipincang terbalik.

In positive half cycle, diode Q and R are forward biased while P and S are reversed biased

In negative half cycle, diode P and S are forward biased while Q and R are reversed biased

35 C

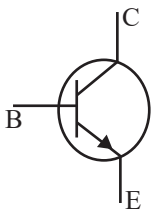

C – Pengumpul / Collector

B – Tapak / Base

E – Pemancar / Emitter

36 B $T_{\frac{1}{2}} = 6 \text{ jam / hours}$

Separuh hayat / Number of half-life = $\frac{18}{6} = 3T_{\frac{1}{2}}$

65 000 $\xrightarrow{T_{\frac{1}{2}}}$ 32 500 $\xrightarrow{T_{\frac{1}{2}}}$ 16 250 $\xrightarrow{T_{\frac{1}{2}}}$ 8 125

37 A $E = mc^2$

E – Jumlah tenaga yang dibebaskan

Total energy released

m – Cacat jisim

Mass defect

c – Laju cahaya

Speed of light

38 D

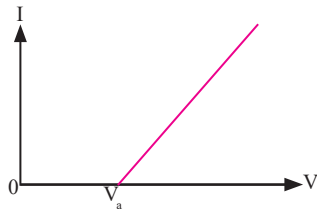

– Voltan pengaktifan, V_a boleh diperoleh melalui pintasan-V daripada graf I melawan V.

The activation voltage, V_a can be obtained through V-intercept from the graph of I against V.

– Nilai pintasan-V bagi B lebih besar daripada A. Jadi nilai pengaktifan B lebih besar daripada A

The value of V-intercept for B is greater than A. So, the activation value of B is greater than A

39 A Elektron tidak terpancar dari permukaan logam kecuali frekuensi gelombang cahaya tuju lebih besar daripada nilai frekuensi ambang logam itu.

Electrons are not emitted from the metal surface unless the frequency of the light wave is greater than the critical value of threshold frequency of the metal.

40 C $W = 3.7 \times 1.6 \times 10^{-19} \text{ J}$
 $= 5.92 \times 10^{-19} \text{ J}$

$W = hf_0$

$5.92 \times 10^{-19} = 6.63 \times 10^{-34} (f_0)$

$f_0 = 8.93 \times 10^{14} \text{ Hz}$

Bahagian A/Section A

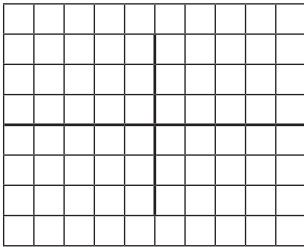
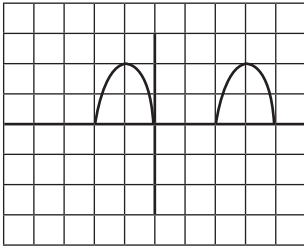
Soalan Questions		Jawapan Answers	Sub markah Subs marks	Jumlah markah Total marks
1	(a)	✓ – kesan fotoelektrik <i>photoelectric effect</i>	1	4
	(b)	Frekuensi ambang <i>Threshold frequency</i>	1	
	(c)	– Keamatan bertambah <i>Intensity increases</i> – Bilangan elektron bertambah <i>Number of electrons increases</i>	1 1	
2	(a)	Pincang depan <i>Forward biased</i>	1	5
	(b)	– Lapisan susutan nipis <i>Depletion layer thin</i> – Voltan simpang berkurang <i>Junction voltage decreases</i> – Rintangan diod berkurang <i>Resistance of diode decrease</i> (Mana-mana dua jawapan) <i>(Any two answers)</i>	1 1	
	(c)	 Rajah 2.2 (b) <i>Diagram 2.2 (b)</i>  Rajah 2.3 (b) <i>Diagram 2.3 (b)</i>	1 1	
3	(a)	Kadar perubahan sesaran <i>Rate change of displacement</i>	1	
	(b)	Nyah pecutan // Halaju berkurang dengan seragam <i>Deceleration // Uniformly decreasing velocity</i>	1	

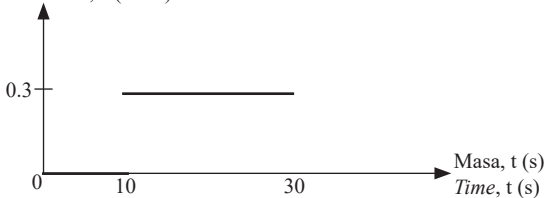
Soalan Questions		Jawapan Answers	Sub markah Subs marks	Jumlah markah Total marks
(c)	Jumlah luas bawah graf <i>Total area under the graph:</i> $= (10 \times 10) + \left[\frac{1}{2} \times (10 + 16) \times 20 \right] + \left(\frac{1}{2} \times 20 \times 16 \right)$ $= 100 + 260 + 160$ $= 520 \text{ m}$		1 1	6
(d)	Pecutan, a (m s ⁻²) <i>Acceleration, a (m s⁻²)</i>  <i>Garis mengufuk pada a = 0 ms⁻² untuk t = (0 – 10 s) – 1 markah</i> <i>Horizontal line at a = 0 ms⁻² for t = (0 – 10 s) – 1 mark</i> <i>Garis mengufuk pada a = 0.3 ms⁻² untuk t = (10 – 30 s) – 1 markah</i> <i>Horizontal line at a = 0.3 ms⁻² for t = (10 – 30 s) – 1 marks</i>		2	
4	(a) Hukum Kepler Kedua <i>Kepler's Second Law</i>		1	9
(b)	– Luas AFB = Luas CFD <i>Area AFB = Area CFD</i> – Masa sama dari A ke B dan C ke D <i>Same amount of time from A to B and from C to D</i> – Laju A ke B > Laju C ke D <i>Linear speed from A to B > linear speed from C to D</i>		1 1 1	
(c)	$\frac{T_P^2}{r_P^3} = \frac{T_E^2}{r_E^3}$ $r_P = 20r_E$ $\frac{T_P^2}{(20r_E)^3} = \frac{1}{r_E^3}$ $T_P = \sqrt{\frac{8000r_E^3}{r_E^3}} (1)$ $= 89.44 \text{ tahun / years}$		1 1 1	
(d)	– Halaju semakin berkurang. <i>Velocity is decreasing.</i> – Masa yang lebih lama diambil untuk melengkapkan satu sektor orbit mengelilingi Matahari. <i>A longer time is taken to complete one sector of orbit around the Sun.</i>		1 1	
5	(a) Tekanan <i>Pressure</i>		1	
(b)	(i) Haba: Rajah 5.1(b) > Diagram 5.1(a) <i>Heat: Diagram 5.1(b) > Diagram 5.1(a)</i>		1	
(ii)	Suhu gas: Rajah 5.1(b) > Rajah 5.1(a) <i>Temperature of gas: Diagram 5.1(b) > Diagram 5.1(a)</i>		1	

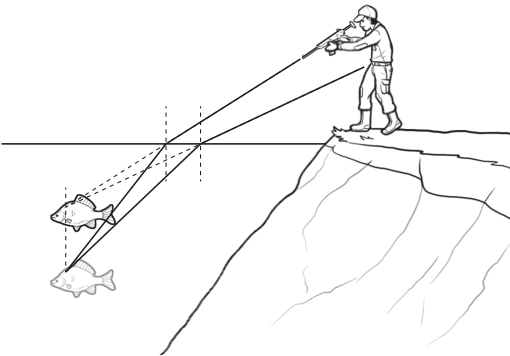
Soalan Questions		Jawapan Answers	Sub markah Subs marks	Jumlah markah Total marks	
	(iii)	Isi padu gas: Rajah 5.1(b) > Rajah 5.1(a) <i>Volume of gas: Diagram 5.1(b) > Diagram 5.1(a)</i>	1		
(c)	(i)	Haba bertambah, suhu bertambah <i>Heat increase, temperature increase</i>	1		
	(ii)	Suhu bertambah, isi padu gas bertambah <i>Temperature increase, volume of gas increase</i>	1		
(d)	Hukum Charles <i>Charles' law</i>	1			
(e)	$\frac{V_1}{T_1} = \frac{V_2}{T_2}$ $\frac{0.035}{35 + 273} = \frac{V_2}{65 + 273}$ $V_2 = 0.038 \text{ m}^3$	1 1	9		
6	(a)	Pembiasan <i>Refraction</i>	1		
	(b)	(i)	Sudut pembiasan: Rajah 6.1(a) < 6.1(b) <i>Refraction angle: Diagram 6.1(a) < Diagram 6.1(b)</i>		1
		(ii)	Ketumpatan medium: Rajah 6.1(a) < Rajah 6.1(b) <i>Density of medium: Diagram 6.1(a) < Diagram 6.1(b)</i>		1
		(iii)	Bentuk asal pen: Rajah 6.1(a) = Rajah 6.1(b) <i>Original shape of pen: Diagram 6.1(a) = Diagram 6.1(b)</i>		1
	(c)	(i)	Ketumpatan bertambah, indeks pembiasan bertambah <i>Density of liquid increases, refractive index increases</i>		1
		(ii)	Ketumpatan bertambah, sudut pembiasan bertambah. <i>Density increases, angle of refraction increases.</i>		1
	(d)	(i)	 <p>Sinar pertama ialah garis lurus dari senapang ke imej ikan. <i>The first ray is a straight line from the gun to the image of the fish.</i> Sinar kedua ialah dari lelaki kepada ikan. Sinar dibengkokkan ke arah normal. <i>The second ray is from the man to the fish. The ray is bent towards the normal.</i> Lukis kedudukan ikan sebenar di mana ikan berada di bawah gambar. <i>Draw the actual position of the fish which is below the image.</i></p>		1 1
(ii)	Dia patut menembak beberapa cm di bawah imej ikan itu. <i>He should shoot a few cm below the image of the fish.</i>	1	9		

Soalan Questions		Jawapan Answers	Sub markah Subs marks	Jumlah markah Total marks	
7	(a)	Penghasilan daya gerakan elektrik dalam konduktor apabila ia memotong fluks magnetik <i>The production of an electromotive force in a conductor when it cuts magnetic flux</i>	1	9	
	(b)	Diod <i>Diode</i>	1		
	(c)	$V_p I_p = V_s I_s$ $(240)I_p = (12)(0.85)$ $I_p = 0.0425 \text{ A}$	1 1		
	(d)	(i)	– Bentuk – 8 <i>8 – shape</i>		1
			– Medan magnet yang dihasilkan oleh gegelung primer melalui gegelung sekunder sepenuhnya <i>Magnetic field produced by the primary coil passes completely through the secondary coil</i>		1
		(ii)	– Lebih banyak lapisan nipis <i>More thin layers</i>		1
		– Mengurangkan arus pusar <i>Reduces eddy currents</i>	1		
(iv)	Transfomer Z <i>Transformer Z</i>	1			
8	(a)	Prinsip Bernoulli <i>Bernoulli's Principle</i>	1	9	
	(b)	Daya angkat = Berat kapal terbang <i>Lift force = Weight of aeroplane</i>	1 1		
		Tekanan/ Pressure = $\frac{5.8 \times 10^6}{500}$ $= 1.16 \times 10^4 \text{ Pa}$			
	(c)	(i)	– Saiz bola pemicit perlulah besar. <i>Size of the squeeze bulb should be large.</i>		1
			– Lebih banyak udara boleh ditolak ke dalam tiub tengah. <i>More air can be squeezed through the mid tube.</i>		1
		(ii)	– Tiub tengah itu mestilah sempit. <i>The mid tube must be narrow.</i>		1
		– Udara mengalir melalui tiub sempit dengan kelajuan tinggi. Tekanannya rendah. Oleh itu, pewangi ditolak keluar. <i>The air flows through the narrow tube with high speed. The pressure is low. Hence, the perfume can be forced out.</i>	1		
(iii)	– Saiz muncung adalah sempit. <i>Size of the nozzle is narrow.</i>	1			
	– Supaya tekanannya tinggi. Semburan dapat bergerak dengan jauh. <i>So that the pressure is high. The spray can go far.</i>	1			

Bahagian B/Section B

Soalan Questions		Jawapan Answers	Sub markah Subs marks	Jumlah markah Total marks												
9	(a)	(i) Pembiasan gelombang <i>Refraction of wave</i>	1													
		(ii) – Gelombang air merambat dari kawasan dalam ke kawasan cetek / Kedalaman berkurang <i>Water waves propagate from deep to shallow areas / Depth decreases</i>	1													
		– Halaju berkurang // Panjang gelombang berkurang <i>Velocity decreases // Wavelength decreases</i>	1													
		– Gelombang air terbias menghampiri garis normal // Pembiasan berlaku <i>Refracted water waves approach the normal line // Refraction occurs</i>	1													
	(iii) Berkurang <i>Decreases</i>	1														
	(b)	(i) $\lambda_d = \frac{16}{4} = 4 \text{ cm}$ $\frac{V_d}{\lambda_d} = \frac{24}{4}$ $= 6 \text{ Hz}$	1 1													
		(ii) $f_d = f_s = 6 \text{ Hz}$ $\lambda_s = \frac{9}{3} = 3 \text{ cm}$ $V_s = (6)(3)$ $= 18 \text{ cms}^{-1}$	1 1 1													
		(c)	<table border="1"> <thead> <tr> <th>Aspek/Aspect</th> <th>Sebab/Reason</th> </tr> </thead> <tbody> <tr> <td>Lokasi: Teluk <i>Location: Bay</i></td> <td>Amplitud lebih kecil <i>Amplitude smaller</i></td> </tr> <tr> <td>Saiz celah benteng: Kecil <i>Size of slit of barrier: Small</i></td> <td>Amplitud lebih kecil <i>Amplitude smaller</i></td> </tr> <tr> <td>Ketinggian benteng: Tinggi <i>Height of barrier: High</i></td> <td>Dapat menahan gelombang yang tinggi <i>Can withstand high waves</i></td> </tr> <tr> <td>Permukaan benteng: Kasar <i>Surface of barrier: Rough</i></td> <td>Tenaga gelombang berkurang <i>Wave energy decreases</i></td> </tr> <tr> <td>Pilihan: <i>Choice: B</i></td> <td>Teluk, saiz celah benteng yang kecil, benteng yang tinggi dan permukaan benteng yang kasar. <i>Bay, smaller size of slit, higher barrier and rough surface.</i></td> </tr> </tbody> </table>		Aspek/Aspect	Sebab/Reason	Lokasi: Teluk <i>Location: Bay</i>	Amplitud lebih kecil <i>Amplitude smaller</i>	Saiz celah benteng: Kecil <i>Size of slit of barrier: Small</i>	Amplitud lebih kecil <i>Amplitude smaller</i>	Ketinggian benteng: Tinggi <i>Height of barrier: High</i>	Dapat menahan gelombang yang tinggi <i>Can withstand high waves</i>	Permukaan benteng: Kasar <i>Surface of barrier: Rough</i>	Tenaga gelombang berkurang <i>Wave energy decreases</i>	Pilihan: <i>Choice: B</i>	Teluk, saiz celah benteng yang kecil, benteng yang tinggi dan permukaan benteng yang kasar. <i>Bay, smaller size of slit, higher barrier and rough surface.</i>
	Aspek/Aspect	Sebab/Reason														
	Lokasi: Teluk <i>Location: Bay</i>	Amplitud lebih kecil <i>Amplitude smaller</i>														
Saiz celah benteng: Kecil <i>Size of slit of barrier: Small</i>	Amplitud lebih kecil <i>Amplitude smaller</i>															
Ketinggian benteng: Tinggi <i>Height of barrier: High</i>	Dapat menahan gelombang yang tinggi <i>Can withstand high waves</i>															
Permukaan benteng: Kasar <i>Surface of barrier: Rough</i>	Tenaga gelombang berkurang <i>Wave energy decreases</i>															
Pilihan: <i>Choice: B</i>	Teluk, saiz celah benteng yang kecil, benteng yang tinggi dan permukaan benteng yang kasar. <i>Bay, smaller size of slit, higher barrier and rough surface.</i>															
10	(a)	(i) Untuk mengawal // melaraskan arus <i>To control // adjust the current</i>	1													
		(ii) Panjang wayar <i>Length of wire</i>	1													
		(iii) – Arus mengalir dari B ke C melalui penggelongsor <i>Current flows from B to C through the slider</i>	1													
		– Penggelongsor digerakkan untuk mengubah panjang wayar <i>Slider is move to change the length of the wire</i>	1													
		– Panjang wayar adalah berkadar terus dengan rintangan <i>Length of wire is directly proportional to the resistance</i>	1													

Soalan Questions		Jawapan Answers	Sub markah Subs marks	Jumlah markah Total marks										
		<p>– Panjang wayar adalah berkadar songsang dengan arus <i>Length of wire is inversely proportional to the current</i> (mana-mana 3 jawapan) (any 3 answers)</p>												
(b)	(i)	$E = V + Ir$ $r = \frac{E - V}{I}$ $= \frac{1.5 - 1.1}{0.2}$ $= 2.0 \Omega$	1 1											
	(ii)	$R_{\text{jumlah / total}} = \frac{V}{I}$ $= \frac{1.1}{0.2}$ $= 5.5 \Omega$ $\frac{1}{R_{\text{selari / parallel}}} = \frac{1}{2} + \frac{1}{3}$ $R_{\text{selari / parallel}} = 1.2 \Omega$ $R_{\text{jumlah / total}} = R + R_{\text{selari / parallel}}$ $5.5 = R + 1.2$ $R = 4.3 \Omega$	1 1 1											
(c)		<table border="1"> <thead> <tr> <th>Aspek/Aspect</th> <th>Sebab/Reason</th> </tr> </thead> <tbody> <tr> <td>Bateri disambung secara bersiri <i>Cell connected in series</i></td> <td>Membekal sumber voltan yang lebih tinggi <i>To supply higher voltage</i></td> </tr> <tr> <td>Terminal positif bateri disambung kepada terminal negatif bateri <i>The positive terminal of dry cell is connected to the negative terminal of the cell</i></td> <td>Arus dapat mengalir dalam litar <i>To let current flow in the circuit</i></td> </tr> <tr> <td>Perintang disambung secara bersiri <i>The resistor is connected in series</i></td> <td>Melaraskan beza keupayaan merentasi mentol kepada 2 V supaya mentol-mentol itu bernyala dengan kecerahan normal. <i>To adjust the potential difference across the bulbs to 2 V so that the bulbs can light up with the normal brightness.</i></td> </tr> <tr> <td>Mentol-mentol disambung secara selari <i>Bulbs connected in parallel</i></td> <td>Apabila satu mentol terbakar, mentol-mentol lain masih menyala <i>If one bulb blown out, the other bulbs still light up</i></td> </tr> </tbody> </table>	Aspek/Aspect	Sebab/Reason	Bateri disambung secara bersiri <i>Cell connected in series</i>	Membekal sumber voltan yang lebih tinggi <i>To supply higher voltage</i>	Terminal positif bateri disambung kepada terminal negatif bateri <i>The positive terminal of dry cell is connected to the negative terminal of the cell</i>	Arus dapat mengalir dalam litar <i>To let current flow in the circuit</i>	Perintang disambung secara bersiri <i>The resistor is connected in series</i>	Melaraskan beza keupayaan merentasi mentol kepada 2 V supaya mentol-mentol itu bernyala dengan kecerahan normal. <i>To adjust the potential difference across the bulbs to 2 V so that the bulbs can light up with the normal brightness.</i>	Mentol-mentol disambung secara selari <i>Bulbs connected in parallel</i>	Apabila satu mentol terbakar, mentol-mentol lain masih menyala <i>If one bulb blown out, the other bulbs still light up</i>	2 2 2 2	
Aspek/Aspect	Sebab/Reason													
Bateri disambung secara bersiri <i>Cell connected in series</i>	Membekal sumber voltan yang lebih tinggi <i>To supply higher voltage</i>													
Terminal positif bateri disambung kepada terminal negatif bateri <i>The positive terminal of dry cell is connected to the negative terminal of the cell</i>	Arus dapat mengalir dalam litar <i>To let current flow in the circuit</i>													
Perintang disambung secara bersiri <i>The resistor is connected in series</i>	Melaraskan beza keupayaan merentasi mentol kepada 2 V supaya mentol-mentol itu bernyala dengan kecerahan normal. <i>To adjust the potential difference across the bulbs to 2 V so that the bulbs can light up with the normal brightness.</i>													
Mentol-mentol disambung secara selari <i>Bulbs connected in parallel</i>	Apabila satu mentol terbakar, mentol-mentol lain masih menyala <i>If one bulb blown out, the other bulbs still light up</i>													

Soalan Questions			Jawapan Answers	Sub markah Subs marks	Jumlah markah Total marks
		Litar X Circuit X	Bateri disambung secara bersiri, terminal positif bateri disambung kepada terminal negatif bateri, perintang disambung secara bersiri, mentol-mentol disambung secara selari <i>Cell connected in series, the positive terminal of dry cell is connected to the negative terminal of the cell, the resistor is connected in series, bulbs connected in parallel</i>	2	20

Bahagian C / Section C

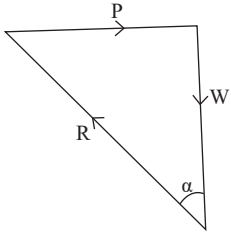
Soalan Questions			Jawapan Answers	Sub markah Subs marks	Jumlah markah Total marks
11	(a)	Daya tunggal yang mewakili jumlah secara vektor dua atau lebih daya yang bertindak ke atas sesuatu objek. <i>Single force represents the sum of two or more forces in vector acted on an object.</i>		1	
	(b)	F_x dalam Rajah 11.1(a) < Rajah 11.1(b) F_x in Diagram 11.1(a) < Diagram 11.1(b)		1	
		W_x dalam Rajah 11.1(a) < Rajah 11.1(b) W_x in Diagram 11.1(a) < Diagram 11.1(b)		1	
		Sudut θ dalam Rajah 11.1(a) < Rajah 11.1(b) <i>Angle θ in Diagram 11.1(a) < Diagram 11.1(b)</i>		1	
		Semakin bertambah sudut, θ , semakin bertambah F_x <i>Angle, θ increase, F_x increase</i>		1	
		Semakin bertambah sudut, θ , semakin bertambah pecutan <i>Angle, θ increase, acceleration increase.</i>		1	
	(c)	 <p>Lukis dan label garis W yang betul <i>Draw and label correct line for W</i></p> <p>Lukis dan label garis R yang betul <i>Draw and label correct line for R</i></p> <p>Tandakan arah W dan R yang betul <i>Mark the correct direction of W and R</i></p> <p>Kedudukan α dan bentuk segi tiga yang betul <i>Correct position of α and shape of triangle</i></p>		1	
				1	
				1	
				1	

Soalan Questions		Jawapan Answers		Sub markah Subs marks	Jumlah markah Total marks
(d)	Aspek/Aspect	Sebab/Reason		2	20
	Menolak mesin rumput <i>Pushing the lawn mover</i>	Daya yang besar dikenakan ke atas rumput <i>Greater force is applied on the grass</i>			
	Jisim besar <i>Large mass</i>	Lebih stabil <i>More stable</i>			
	Bilah pemotong yang besar <i>Bigger cutter blade</i>	Lebih banyak rumput boleh dipotong <i>More grass can be cut</i>			
	Sudut yang luas <i>Larger angle</i>	Untuk menghasilkan daya bertindak ke bawah yang besar <i>To produce large force acting downward</i>			
	Tangki bahan api besar <i>Large fuel tank</i>	Memotong rumput lebih lama. <i>Cutting grass for longer time.</i>			