

KERTAS SOALAN PEPERIKSAAN SEBENAR SPM 2021-2022

FORMAT TERKINI

+2 SET
KERTAS MODEL
FORMAT INSTRUMEN
SPM TERKINI

FIZIK

Dwibahasa

SIJIL PELAJARAN MALAYSIA 2021

Kertas 1 / Paper 1

- 1 **C** Kuantiti asas: panjang, jisim, masa, suhu termodinamik, arus elektrik, keamatan berluminesensi dan jumlah bahan
Base quantity: length, mass, time, thermodynamic temperature, electric current, luminous intensity and amount of substance
- 2 **B** Disebabkan inersia, pemandu dan penumpang akan terus bergerak ke hadapan dengan halaju tetap dan menghentam stereng dan cermin hadapan apabila kereta berhenti secara tiba-tiba.
Due to inertia, the driver and passengers will continue moving forward with constant velocity and hit the steering or windscreen when the car stops in a sudden.
- 3 **A** Daripada persamaan $s = ut + \frac{1}{2}gt^2$, apabila s tetap dan u sifar, g berkadar songsang dengan t . Kekuatan medan graviti, g Bulan adalah lebih rendah berbanding Bumi, maka masa yang diambil untuk kotak sampai ke permukaan, t adalah lebih panjang.
From the equation $s = ut + \frac{1}{2}gt^2$, when s constant and u zero, g is inversely proportional to t . Gravitational field strength, g on the Moon is less than that on Earth, hence the time taken by the box to reach the surface, t are longer.
- 4 **B** Kecerunan graf sesaran-masa menunjukkan halaju objek.
0 – P: Halaju malar, 1 m s^{-1}
PQ: Halaju sifar, 0 m s^{-1}
QRS: Halaju malar (pada arah bertentangan), -1 m s^{-1}
Gradient of a displacement-time graph shows velocity of object.
0 – P: Constant velocity, 1 m s^{-1}
PQ: Zero velocity, 0 m s^{-1}
QRS: Constant velocity (opposite direction), -1 m s^{-1}
- 5 **A** $v^2 = u^2 + 2gs$
 $= 0 + 2(9.81)(5)$
 $v = 9.9045 \text{ m s}^{-1}$



- 6 C Daripada persamaan $v = \sqrt{\frac{2GM}{r}}$, halaju lepas dipengaruhi oleh jisim Bumi, M dan jarak objek dari pusat Bumi, r.
From the equation $v = \sqrt{\frac{2GM}{r}}$, escape velocity is influenced by the mass of the Earth, M and the distance of the object from the centre of Earth, r.
- 7 B Apabila $r < R$, nilai g berkadar terus dengan jarak dari pusat Bumi. Apabila $r \geq R$, nilai g berkadar songsang dengan jarak dari pusat Bumi.
When $r < R$, the value of g is directly proportional to the distance from the centre of the Earth. When $r \geq R$, the value of g is inversely proportional to the distance from the centre of the Earth.
- 8 B Ciri-ciri satelit bukan geopegun: Arah putarannya tidak semestinya sama dengan arah putaran Bumi, tempoh orbitnya melebihi atau kurang daripada 24 jam, kedudukannya berada di atas kedudukan geografi yang berubah-ubah di permukaan Bumi serta digunakan untuk pengimejan Bumi, GPS dan ramalan cuaca.
Characteristics of non-geostationary satellite: Direction of rotation need not be the same as the direction of the Earth rotation, orbit period can be more or less than 24 hours, the position of satellite is above the changing locations on the surface of the Earth and use for earth imaging, GPS and weather forecast.
- 9 C Daya graviti/Gravitational force:

$$F = \frac{GMm}{r^2}$$

$$= \frac{(6.67 \times 10^{-11})(5.94 \times 10^{24})(54)}{(6.37 \times 10^6)^2}$$

$$= 527.26 \text{ N}$$
- 10 C Daripada $FD = mv^2$, $v^2 = \frac{1}{m} FD$, di mana FD ialah kecerunan (malar)
From $FD = mv^2$, $v^2 = \frac{1}{m} FD$, where FD is the gradient (constant)
- 11 A Hukum Charles: Apabila suhu gas berkurang, tenaga kinetik purata molekul berkurang dan kadar perlanggaran antara molekul udara dengan dinding botol berkurang, halaju berkurang. Untuk mengekalkan tekanan, isi padu gas berkurang (jarak antara molekul udara berkurang), maka kadar perlanggaran molekul dan dinding botol tidak berubah.
Charles law: When the temperature of gas decreased, the average kinetic energy of molecules decreases and the rate of collision between air molecules and the inner wall of the bottle decreases, velocity decreases. To maintain the pressure, the volume of the gas decreases, so that the rate of collision between the gas and the inner wall of the bottle does not change.
- 12 A Haba pendam pelakuran suatu bahan ialah kuantiti haba yang diserap semasa peleburan atau dibebaskan semasa pembekuan bahan tanpa perubahan suhu.
Latent heat of fusion of a substance is the quantity of heat absorbed during melting or released during solidification of the substance without a change in temperature.
- 13 B Panjang K sama dengan panjang X, maka frekuensi aslinya sama dengan frekuensi X.
Length of K is equal to length of X, therefore the natural frequency is equal to frequency X.
- 14 C Fenomena pembiasan. Panjang gelombang berkurang apabila kedalaman berkurang.
Phenomenon is refraction. Wavelength decreases when depth decreases.
- 15 A Frekuensi gelombang ultrasonik melebihi 20 kHz digunakan dalam telekomunikasi jarak dekat.
Frequency of ultrasonic wave exceeds 20 kHz, used in short range telecommunications.
- 16 A $u = 2f$
 Ciri-ciri imej: Nyata, songsang dan sama saiz.
Characteristics of image: Real, inverted and same size.

17 D Daripada rajah dan $m = \frac{v}{u} = \frac{h_i}{h_o}$, jarak objek, u berkadar songsang dengan ketinggian imej, h_i .

From diagram and $m = \frac{v}{u} = \frac{h_i}{h_o}$, object distance, u is inversely proportional to the height of image, h_i .

18 D Imej dari kanta kamera: Jarak objek dekat menghasilkan imej yang besar, jarak objek yang jauh menghasilkan imej yang kecil.

Image from camera lens: Object distance shorter produced bigger image, object distance longer produced smaller image.

19 B Daripada gabungan / From combination of $\frac{1}{f} = \frac{1}{u} + \frac{1}{v}$ dan / and $m = \frac{v}{u}$ ($u = \frac{v}{m}$);

$$\frac{1}{f} = \frac{1}{u} + \frac{1}{v}$$

$$\frac{1}{f} = \frac{1}{\frac{v}{m}} + \frac{1}{v}$$

$$\frac{1}{f} = \frac{m}{v} + \frac{1}{v}$$

$$\frac{1}{f} = \frac{m+1}{v}$$

$v = fm + f$, f ialah pintasan- y , X

f is y -intercept, X

20 B $F_x = 500 \cos 60^\circ$
 $= 250$

21 D Daripada $F = ma$, pecutan, a berkadar songsang dengan jisim, m .

From $F = ma$, acceleration, a is inversely proportional to the mass, m .

22 D $F_{\text{net}} = 1\,000 \sin 30^\circ + 850 - 150$
 $= 500 \text{ N} + 850 \text{ N} - 150 \text{ N}$
 $= 1\,200 \text{ N}$

23 C Ketinggian turus merkuri menunjukkan tekanan atmosfera.

The height of mercury column shows atmospheric pressure.

24 D Faktor yang mempengaruhi tekanan air ialah kedalaman.

Factor that affects water pressure is the depth.

25 D $P = \frac{F}{A}$

$$150 = \frac{F}{200}$$

$$F = 30\,000 \text{ N}$$

26 A $F = ma$

$$W - F_B = ma$$

$$2\,500 - 2\,400 = 250a$$

$$a = 0.4 \text{ m s}^{-2}$$

27 D Apabila beza keupayaan antara plat logam bertambah, kekuatan medan elektrik bertambah.

When potential difference between metal plates increases, electric field strength increases.

- 28 B** Apabila rintangan dawai berkurangan (dawai lebih tebal), arus yang mengalir melalui mentol bertambah.
When resistance decreases (thicker wire), the current flows through bulb increases.
- 29 C**
$$P = \frac{V^2}{R}$$

$$= \frac{240^2}{25}$$

$$= 2\,304\text{ W}$$
- 30 B** Nilai r = kecerunan graf/*Value of r = gradient of the graph:*

$$r = \frac{0.5 - 3.0}{3.0 - 0}$$

$$-r = 0.833\ \Omega$$
- 31 A** Penjana elektrik arus terus menggunakan dua gelang gelincir. Dalam keadaan mendatar, gegelung memotong fluks magnet menghasilkan arus aruhan yang maksimum.
Alternating current generator uses two split rings. In horizontal position, the coil cut the magnetic field and produced maximum alternating current.
- 32 B** Daya lastik bertambah apabila kekuatan medan magnet bertambah dengan menggunakan magnet melengkung.
Catapult force increases when the strength of magnetic field increases by using a curve magnet.
- 33 C** Kecekapan transformer (voltan output tinggi) boleh ditingkatkan dengan mengurangkan kehilangan tenaga dengan menggunakan gegelung dawai kuprum yang tebal, teras besi berlamina, teras besi lembut dan gegelung sekunder melilit gegelung primer.
Efficiency of transformer (higher output voltage) can be increased by reducing energy loss by using thicker copper wire coil, laminated iron core, soft iron core and winding the secondary coil on the primary coil.
- 34 C** Diod hanya membenarkan arus mengalir melalui satu arah (pincang hadapan).
Diode allows current to flow in one direction only (in forward biased).
- 35 C** Rektifikasi gelombang penuh. Dalam kitar separuh positif, arus melalui M-N-T-S.
Full wave rectification. During positive half cycle, current flows through M-N-T-S.
- 36 B** Katod disambungkan ke terminal negatif manakala anod disambungkan ke terminal positif bekalan kuasa. Elektron dibebaskan apabila filamen pada katod dipanaskan. Elektron memecut dengan halaju tinggi menuju ke anod.
Cathode connected to the negative terminal, while anode connected to the positive terminal of the power supply. Electrons released when the filament in cathode was heated. Electrons accelerate at high velocity towards anode.
- 37 A** Mengendalikan bahan radioaktif menggunakan lengan robotik mengurangkan risiko terdedah kepada bahan radioaktif.
Handling radioactive materials using robotic arms reduce the risks of being exposed to the radioactive materials.
- 38 D** Fungsi rod kawalan boron: Menyerap neutron berlebihan. Fungsi moderator grafit: Memperlambatkan kelajuan neutron.
Function of the boron control rod: Absorb the excessive neutron. Function of the graphite moderator: Slows down the speed of neutron.
- 39 C** Tenaga nuklear merupakan sumber tenaga bersih yang tidak memberi kesan kepada ekosistem dan jejak karbon.
Nuclear energy is clean and no effect to the ecosystem and carbon footprint.
- 40 C** Nukleus yang lebih ringan (Hidrogen) bergabung membentuk satu nukleus yang lebih berat dan membebaskan tenaga yang tinggi.
Lighter nuclei (Hydrogen) fuse together to form a single heavier nucleus and releasing enormous energy.

Bahagian A/Section A

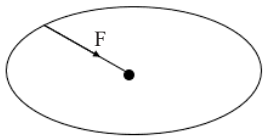
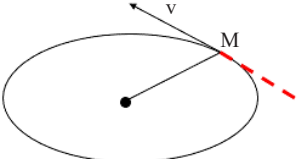
Soalan Questions		Jawapan Answers	Sub markah Subs marks	Markah total Total marks
1	(a)	(i) ✓ Haba pendam/Latent heat	1	4
		(ii) Cecair dan pepejal/Liquid and solid	1	
		(iii) Tenaga kinetik tidak berkurang/sama/malar/tetap/tidak berubah Kinetic energy not decreased/same/constant/remain/not changed	1	
	(b) Tenaga haba dibebaskan/hilang/keluar/dilesapkan Heat energy released/lost/out/dissipated	1		
2	(a)	Frekuensi minimum untuk menghasilkan kesan fotoelektrik Minimum frequency to produce photoelectric effect	1	5
	(b)	$(6.6 \times 10^{-34})(9 \times 10^{14})$ (Gantian yang betul/Correct substitution) $5.94 \times 10^{-19} \text{ J}$ (Jawapan dan unit yang betul) (Correct answer with unit)	1	
		(c)	Keamatan bertambah, bilangan elektron bertambah. Intensity increases, number of electrons increases.	
3	(a)	(i) Daya memusat/Centripetal force	1	6
		(ii) 	1	
	(iii)  (Arah v tangen pada bulatan) (Direction of v tangent to the circle)	1		
	(b)	$F = \frac{mv^2}{r}$ $= \frac{(0.2)(10)^2}{1.5}$ $= 13.33 \text{ N (minimum 2 t.p./minimum 2 d.p.)}$	2	
(c)	Bertambah/Increases	1		
4	(a)	(i) Suis automatik/Automatic switch	1	3
		(ii) $V_1 = \frac{R_1}{R_1 + R_2} \times V$ $1.2 = \frac{R_1}{R_1 + 10\,000} \times 6$ $R_1 = 2.5 \text{ k}\Omega$ (Jawapan dan unit yang betul) (Correct answer with unit)	3	

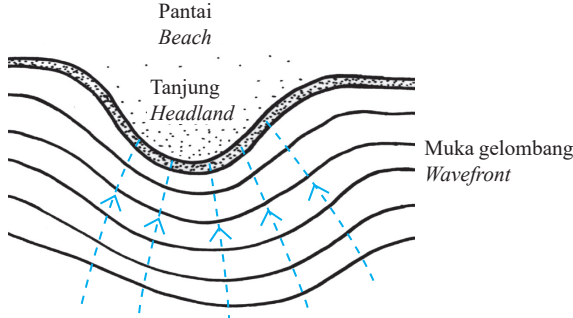
Soalan Questions		Jawapan Answers	Sub markah Subs marks	Markah total Total marks	
	(iii)	$\frac{5 \times 10^{-3}}{50 \times 10^{-6}} = 100$ (Gantian yang betul/Correct substitution) (Jawapan yang betul/Correct answer)	1 1	9	
	(b)	<ul style="list-style-type: none"> – Rintangan PPC bertambah <i>Resistance of LDR increased</i> – Voltan tapak bertambah <i>Base voltage increased</i> – Arus tapak, I_b mengalir <i>Base current, I_b flow</i> – Transistor diaktifkan <i>Transistor activated</i> – Arus pengumpul mengalir <i>Collector current flow</i> (Maksimum 3 markah/Maximum 3 marks)	3		
5	(a)	✓ gelombang melintang/transverse wave	1	9	
	(b)	(i)	Kedalaman air di kawasan Y > kawasan X//sebaliknya <i>The depth of water in region Y > region X//vice versa</i>		1
		(ii)	Panjang gelombang di kawasan Y > kawasan X//sebaliknya <i>The wavelength in region Y > region X//vice versa</i>		1
		(iii)	Frekuensi gelombang air di kawasan X dan kawasan Y tidak berubah <i>The frequency of water wave in region X dan region Y are not change</i>		1
	(c)	Semakin bertambah kedalaman air, semakin bertambah panjang gelombang//sebaliknya <i>The depth of water increases, the wavelength increase//vice versa</i>	1		
	(d)	Pembiasan/Refraction	1		
	(e)	(i)	 <p>(Minimum 2 garis melengkung yang menumpu ke arah tanjung dalam julat garis putus-putus) <i>(Minimum 2 curved lines converged to the cape in the range of the dashed lines)</i></p>		1
(ii)		$\frac{v_1}{\lambda_1} = \frac{v_2}{\lambda_2}$ $v_2 = \frac{(20)(2.5)}{8}$ $= 6.25 \text{ m s}^{-1}$	2		
6	(a)	Peraturan Tangan Kiri Fleming <i>Fleming's Left Hand Rule</i>	1	1	
	(b)	(i) Ketebalan dawai kuprum 6.1(b) > 6.1(a)//sebaliknya <i>The thickness of the copper wire 6.1(b) > 6.1(a)//vice versa</i>	1		

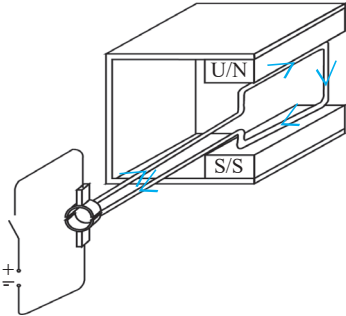
Soalan Questions		Jawapan Answers	Sub markah Subs marks	Markah total Total marks
	(ii)	Saiz sudut ayunan dawai kuprum $6.1(b) > 6.1(a)$ //sebaliknya <i>The size of swing angle of the copper wire $6.1(b) > 6.1(a)$//vice versa</i>	1	9
	(iii)	Daya yang bertindak ke atas dawai kuprum $6.1(b) > 6.1(a)$ //sebaliknya <i>The force that acted on the copper wire $6.1(b) > 6.1(a)$//vice versa</i>	1	
(c)	(i)	Semakin bertambah ketebalan dawai kuprum, semakin bertambah daya yang bertindak ke atas dawai kuprum//sebaliknya <i>The thickness of the copper wire increases, the force acted on the copper wire increases//vice versa</i>	1	
	(ii)	Semakin bertambah saiz sudut ayunan dawai kuprum, semakin bertambah daya yang bertindak ke atas dawai kuprum//sebaliknya <i>The size of swing angle of copper wire increases, the force acted on the copper wire increases//vice versa</i>	1	
(d)		Arah bertentangan/berlawanan/songsang/ke kiri/ke dalam <i>Opposite direction/to the left/inwards</i>	1	
(e)	(i)	 <p>Arah arus betul pada mana-mana bahagian pada gegelung <i>Direction of current correct at any parts on the coil</i></p>	1	
	(ii)	Lawan arah jam/ <i>Anti-clockwise direction</i>	1	
7	(a)	Nukleus berat pecah kepada dua nukleus yang lebih ringan yang sama jisim//berjisim kecil. <i>Heavy nucleus split into two nucleus of equal mass//lighter mass.</i>	1	
	(b)	(i) $0.198264 \times (1.66 \times 10^{-27})$ $= 3.291 \times 10^{-28} \text{ kg}$	1	
		(ii) $E = mc^2$ $= (3.291 \times 10^{-28})(3 \times 10^8)^2$ $= 2.961 \times 10^{-11} \text{ J}$ (Gantian yang betul/ <i>Correct substitution</i>) (Jawapan dan unit yang betul/ <i>Correct answer with unit</i>)	1 1	
	(c)	(i) Boron/Boron: • Kawal kadar tindak balas//Kawal kadar pembelahan nukleus//Serap neutron berlebihan <i>Control rate of reaction//Control rate of nucleus fission//Absorb excessive neutrons</i>	2	
		(ii) Grafit/Graphite: • Perlahankan neutron//Kawal halaju neutron//Kawal tenaga kinetik neutron <i>Slow down neutron//Control velocity of neutron//Control kinetic energy of neutron</i>	2	
	(d)	K	1	
8	(a)	Pantulan dalam penuh/ <i>Total internal reflection</i>	1	9

Soalan Questions		Jawapan Answers	Sub markah Subs marks	Markah total Total marks
(b)		$n = \frac{1}{\sin c}$ $1.5 = \frac{1}{\sin c}$ $c = 41.81^\circ \text{ (min. 2 t.p./min. 2 d.p.)}$	2	9
(c)	(i)	Kecil//Rendah. Lebih banyak pantulan dalam penuh berlaku. <i>Small//Low. More total internal reflection occurs.</i>	2	
	(ii)	Tinggi//Tumpat. Indeks biasan tinggi//Sudut genting kecil//Lebih banyak pantulan dalam penuh berlaku. <i>High//Denser. High refractive index//Small critical angle//More total internal reflection occurs.</i>	2	
	(iii)	Rata//Licin. Lebih banyak pantulan dalam penuh berlaku. <i>Even//Smooth. More total internal reflection occurs.</i>	2	

Bahagian B/Section B

Soalan Questions		Jawapan Answers	Sub markah Subs marks	Markah total Total marks
9	(a)	Daya graviti/ <i>Gravitational force</i>	1	9
	(b)	$\frac{\sin 60^\circ}{15} = \frac{\sin 60^\circ}{T}$ $T = 15 \text{ N}$ <p style="text-align: center;">atau/or</p> $W^2 = T^2 + T^2 - 2(T \times T \cos/\cos 60^\circ)$ $W^2 = 2T^2 - 2T^2 \cos/\cos 60^\circ$ $15^2 = 2T^2 - T^2$ $T^2 = 15^2$ $T = 15 \text{ N}$	4	
	(c)	(i) $s = ut + \frac{1}{2}gt^2$ $4 = 0 + \frac{1}{2}(9.81)t^2$ $t = 0.903 \text{ s}$ (Gantian yang betul/ <i>Correct substitution</i>) (Jawapan dan unit betul, min 2 t.p.) (<i>Correct answer with unit, min. 2 d.p.</i>)	1 1	
		(ii) $v = u + gt$ $= 0 + (9.81)(0.903)$ $= 8.86 \text{ m s}^{-1}$ <p style="text-align: center;">atau/or</p> $v^2 = u^2 + 2gh$ $= 0 + 2(9.81)(4)$ $v = 8.86 \text{ m s}^{-1}$ <p style="text-align: center;">atau/or</p>		

Soalan Questions		Jawapan Answers	Sub markah Subs marks	Markah total Total marks												
		$s = \frac{1}{2}(u + v)t$ $4 = \frac{1}{2}(0 + v)(0.903)$ $v = 8.86 \text{ m s}^{-1}$ <p style="text-align: center;">atau/or</p> $mgh = \frac{1}{2}mv^2$ $v = \sqrt{2gh}$ $= \sqrt{2 \times 9.81 \times 4}$ $= 8.86 \text{ m s}^{-1}$	2	20												
	(iii)	Daya impuls besar//Kadar perubahan momentum tinggi//Masa hentaman pendek <i>Greater impulsive force//High rate of change of momentum//Shorter time of impact</i>	1													
	(d)	<table border="1" style="width: 100%; border-collapse: collapse;"> <thead> <tr> <th style="text-align: center;">Ciri-ciri Characteristics</th> <th style="text-align: center;">Sebab Reason</th> </tr> </thead> <tbody> <tr> <td>Sudut, θ kecil <i>Small angle, θ</i></td> <td>Daya tinggi <i>High force</i></td> </tr> <tr> <td>Kabel tidak kenyal <i>Inelastic cable</i></td> <td>Daya seragam//Panjang kabel tetap//Kabel tidak menegang <i>Uniform force//Length of cable remain//Cable not stretched</i></td> </tr> <tr> <td>Tegangan maksimum tinggi <i>High maximum tension</i></td> <td>Menampung daya tinggi//Tidak putus//Tahan lasak//Kuat <i>Support high force//Not snap //Durable//Strong</i></td> </tr> <tr> <td>Papan kayu <i>Wooden plank</i></td> <td>Kurang tekanan//Tambah luas permukaan/sentuhan. <i>Less pressure//Increase surface/contact area</i></td> </tr> <tr> <td colspan="2">Pilih S kerana sudut, θ kecil, kabel tidak kenyal, tegangan maksimum tinggi dan papan kayu. <i>Choose S because small angle, θ, inelastic cable, high maximum tension and wooden plank.</i></td> </tr> </tbody> </table>	Ciri-ciri Characteristics		Sebab Reason	Sudut, θ kecil <i>Small angle, θ</i>	Daya tinggi <i>High force</i>	Kabel tidak kenyal <i>Inelastic cable</i>	Daya seragam//Panjang kabel tetap//Kabel tidak menegang <i>Uniform force//Length of cable remain//Cable not stretched</i>	Tegangan maksimum tinggi <i>High maximum tension</i>	Menampung daya tinggi//Tidak putus//Tahan lasak//Kuat <i>Support high force//Not snap //Durable//Strong</i>	Papan kayu <i>Wooden plank</i>	Kurang tekanan//Tambah luas permukaan/sentuhan. <i>Less pressure//Increase surface/contact area</i>	Pilih S kerana sudut, θ kecil, kabel tidak kenyal, tegangan maksimum tinggi dan papan kayu. <i>Choose S because small angle, θ, inelastic cable, high maximum tension and wooden plank.</i>		2 2 2 2
Ciri-ciri Characteristics	Sebab Reason															
Sudut, θ kecil <i>Small angle, θ</i>	Daya tinggi <i>High force</i>															
Kabel tidak kenyal <i>Inelastic cable</i>	Daya seragam//Panjang kabel tetap//Kabel tidak menegang <i>Uniform force//Length of cable remain//Cable not stretched</i>															
Tegangan maksimum tinggi <i>High maximum tension</i>	Menampung daya tinggi//Tidak putus//Tahan lasak//Kuat <i>Support high force//Not snap //Durable//Strong</i>															
Papan kayu <i>Wooden plank</i>	Kurang tekanan//Tambah luas permukaan/sentuhan. <i>Less pressure//Increase surface/contact area</i>															
Pilih S kerana sudut, θ kecil, kabel tidak kenyal, tegangan maksimum tinggi dan papan kayu. <i>Choose S because small angle, θ, inelastic cable, high maximum tension and wooden plank.</i>																
10	(a)	Kadar pengaliran cas/ <i>Rate of flow of charge</i>	1													
	(b) (i)	$P = \frac{V^2}{R}$ $1\,000 = \frac{240^2}{R}$ $R = 57.6 \text{ ohm } // \Omega$	3													
	(ii)	$P = I^2 R$ $= 4.2^2 \times 57.6$ $= 1\,016.064 \text{ W (min. 2 t.p./min at 2 d.p.)}$	2													
	(c)	<ul style="list-style-type: none"> – Tenaga elektrik ditukarkan kepada tenaga haba. <i>Electrical energy converted into heat energy.</i> – Elemen pemanas berbentuk gegelung. <i>Coiled shaped heating element.</i> 														

Soalan Questions		Jawapan Answers	Sub markah Subs marks	Markah total Total marks										
		<ul style="list-style-type: none"> – Panjang elemen pemanas bertambah, rintangan bertambah. <i>Length of heating element increases, resistance increases.</i> – Rintangan hasilkan haba. <i>Resistance produced heat.</i> – Haba yang tinggi dihasilkan. <i>A lot of heat produced.</i> – Haba dipindahkan ke periuk//Periuk serap haba dari elemen pemanas. <i>Heat is transferred to the pot//Pot absorbed heat from the heating element.</i> (Max. 4m)	4											
(d)	<table border="1"> <thead> <tr> <th>Cadangan Suggestions</th> <th>Sebab Reason</th> </tr> </thead> <tbody> <tr> <td>Bentuk dawai perintang – Bergelung <i>Shape of resistance wire – Coiled</i></td> <td>Rintangan tinggi//Panjang//Banyak haba <i>Higher resistance//Long//More heat</i></td> </tr> <tr> <td>Kerintangan dawai perintang – Tinggi <i>Resistivity of resistance wire – High</i></td> <td>Lebih haba//Rintangan tinggi <i>More heat//High resistance</i></td> </tr> <tr> <td>Bahan dawai perintang – Nikrom <i>Material of resistance wire – Nichrome</i></td> <td>Takat lebur tinggi//Rintangan tinggi//Banyak haba <i>High melting point//High resistance//More heat</i></td> </tr> <tr> <td>Bahan salutan luar – Keluli <i>Casing material – Steel</i></td> <td>Tidak teroksida//Tahan suhu tinggi//Konduktor haba yang baik <i>Not oxidise//Withstand high temperature//Good heat conductor</i></td> </tr> </tbody> </table>	Cadangan Suggestions	Sebab Reason		Bentuk dawai perintang – Bergelung <i>Shape of resistance wire – Coiled</i>	Rintangan tinggi//Panjang//Banyak haba <i>Higher resistance//Long//More heat</i>	Kerintangan dawai perintang – Tinggi <i>Resistivity of resistance wire – High</i>	Lebih haba//Rintangan tinggi <i>More heat//High resistance</i>	Bahan dawai perintang – Nikrom <i>Material of resistance wire – Nichrome</i>	Takat lebur tinggi//Rintangan tinggi//Banyak haba <i>High melting point//High resistance//More heat</i>	Bahan salutan luar – Keluli <i>Casing material – Steel</i>	Tidak teroksida//Tahan suhu tinggi//Konduktor haba yang baik <i>Not oxidise//Withstand high temperature//Good heat conductor</i>	2	2
Cadangan Suggestions	Sebab Reason													
Bentuk dawai perintang – Bergelung <i>Shape of resistance wire – Coiled</i>	Rintangan tinggi//Panjang//Banyak haba <i>Higher resistance//Long//More heat</i>													
Kerintangan dawai perintang – Tinggi <i>Resistivity of resistance wire – High</i>	Lebih haba//Rintangan tinggi <i>More heat//High resistance</i>													
Bahan dawai perintang – Nikrom <i>Material of resistance wire – Nichrome</i>	Takat lebur tinggi//Rintangan tinggi//Banyak haba <i>High melting point//High resistance//More heat</i>													
Bahan salutan luar – Keluli <i>Casing material – Steel</i>	Tidak teroksida//Tahan suhu tinggi//Konduktor haba yang baik <i>Not oxidise//Withstand high temperature//Good heat conductor</i>													
			2											
			2											
			2											
		Pilih model L kerana dawai perintang bergelung, kerintangan dawai perintang tinggi, bahan dawai perintang ialah nikrom dan bahan salutan luar ialah keluli. <i>Choose model L because coiled resistance wire, high resistivity of resistance wire, material of resistance wire is nichrome and casing material is steel.</i>	2	20										

Bahagian C/Section C

Soalan Questions		Jawapan Answers	Sub markah Subs marks	Markah total Total marks
11	(a)	Laju bendalir yang mengalir bertambah, tekanan berkurang <i>Speed of a moving fluid increases, pressure decreases</i>	1	
	(b)	<ul style="list-style-type: none"> – Laju air di atas bertambah. <i>Speed of water above increases.</i> – Tekanan di bawah bertambah//sebaliknya. <i>The pressure of water below increases.</i> – Perbezaan tekanan. <i>Pressure difference.</i> – Daya angkat terhasil. <i>Lift force produced.</i> – Daya angkat > berat//daya paduan ke atas <i>Lift force/Lift > weight//resultant force upwards</i> (Max. 4m)	4	
	(c)	<ul style="list-style-type: none"> – Ketinggian papan luncur dari permukaan air pada Rajah 11.3 lebih tinggi//sebaliknya <i>High of the surfboard from the water supply in Diagram 11.3 is higher//vice versa</i> – Daya geseran air yang bertindak ke atas papan luncur pada Rajah 11.3 lebih rendah//sebaliknya <i>Water friction acted on the surfboard in Diagram 11.3 is lower//vice versa</i> – Laju papan luncur pada Rajah 11.3 lebih tinggi//sebaliknya <i>Speed of surfboard in Diagram 11.3 is higher//vice versa</i> – Ketinggian bertambah, daya geseran berkurang//sebaliknya <i>Height of surface increases, frictional force decreases//vice versa</i> – Daya geseran berkurang, laju papan luncur bertambah <i>Water friction decreases, speed of the surface increases</i> 	1 1 1 1 1	

(d)

Cadangan Suggestions	Sebab Reason
Ciri-ciri bot/Characteristic of boat	
– Ketumpatan bot rendah <i>Low density of boat</i>	Ringan//Jisim rendah <i>Light//Low mass</i>
– Bot kuat/kukuh/aluminium/ keluli <i>Strong boat/Aluminium boat/Steel boat</i>	Tidak pecah//Tidak bocor//Kuat// Kukuh//Tahan lasak <i>Not break//Not leak//Strong//Durable</i>
– Jisim bot kecil//Bot ringan <i>Mass of boat small//Boat lighter</i>	Bot pecut <i>Boat accelerates</i>
– Bot aerodinamik <i>Aerodynamic boat</i>	Kurang geseran/rintangan/seretan <i>Less friction/resistance/drag</i>
Saiz bot/Size of boat	
– Besar//Panjang//Luas//Lebar <i>Big//Long//Wide</i>	Terapung//Daya apungan besar// Banyak air tersesar <i>Float//Greater buoyant force// Displaced more water</i>
Ciri-ciri hidrofoil Characteristic of hydrofoil	
– Ketumpatan hidrofoil rendah <i>Low density of hydrofoil</i>	Jisim rendah//Pecut <i>Low mass//Accelerates</i>
– Jisim hidrofoil kecil//Hidrofoil ringan <i>Mass of hydrofoil small//Hydrofoil light</i>	Pecut <i>Accelerates</i>
– Hidrofoil kuat/kukuh/ aluminium/keluli/plastik fiber <i>Strong hydrofoil/Aluminium hydrofoil/Steel hydrofoil/fibre plastic hydrofoil</i>	Tidak pecah//Kuat//Kukuh// Tahan/Tidak karat <i>Not break//Strong//Durable//Not rust</i>
Bilangan hidrofoil Number of hydrofoil	
– Hidrofoil banyak/lebih daripada 2 <i>Many hydrofoil/More than 2</i>	Daya lebih//Kuasa lebih//Tenaga lebih//Momentum lebih//Daya apungan besar <i>More force//More power//More energy//More momentum//Great buoyant force</i>
Kuasa enjin yang digunakan Power of the engine used	
– Besar//Tinggi/Berkuasa tinggi <i>Large//High</i>	Daya besar/tinggi//Lebih daya// Momentum/Tenaga tinggi//Daya apungan besar <i>Big/High force//More force//High momentum/energy//Great buoyant force</i>

Maks. 10 markah daripada mana-mana bahagian.
Max. 10 marks from any parts.

10

20

Kertas 1 / Paper 1

- 1 C Kuantiti asas pada label ialah jisim (55.2 g), suhu (80 °C) dan masa (3 minit)
Base quantities stated in the label are mass (55.2 g), temperature (80 °C) and time (3 minutes)
- 2 C Graf garis lengkung dengan kecerunan negatif dan tidak menyentuh kedua-dua paksi menunjukkan P berkadar songsang dengan V.
Curve line graph with negative gradient and not touching both axes show P is inversely proportional to V.
- 3 C $v = \frac{s}{t}$
 $v = \frac{10\,000\text{ m}}{3\,600\text{ s}}$
 $v = 2.78\text{ m s}^{-1}$
- 4 C Kecerunan graf = Halaju. Kecerunan OP seragam maka halaju OP seragam, manakala kecerunan PQ sifar maka halaju PQ sifar.
Gradient of graph = Velocity. Gradient of OP is uniform thus velocity OP uniform, while gradient of PQ is zero thus velocity PQ zero.
- 5 A Spring X berdiameter besar mempunyai pemalar spring yang kecil (spring lembut), manakala spring Y berdiameter kecil mempunyai pemalar spring yang lebih besar (spring keras). Maka pemanjangan spring X lebih besar berbanding spring Y.
Spring X with a larger diameter has a smaller spring constant (soft spring), while spring Y with a smaller diameter has a larger spring constant. Thus, the extension of spring X is bigger compared to spring Y.
- *Tidak boleh menganggap spring X dan spring Y mempunyai pemalar spring yang sama walaupun keduanya spring keluli kerana soalan tidak menyatakan spring adalah serupa.
**Cannot assume spring X and spring Y has a same spring constant even though both are steel spring as the question does not state that they are identical spring.*
- 6 A Pengurangan jisim bahan api mengurangkan jisim keseluruhan roket, maka pecutan roket bertambah. (menurut $F = ma$, jisim berkadar songsang dengan pecutan)
Reduction in fuel mass causes reduction in total masses of the rocket, thus acceleration of rocket increases. (according to $F = ma$, mass is inversely proportional to acceleration)
- 7 D $J = mv - mu$
 $= (0.02)(5) - (0.02)(-10)$
 $= 0.1 + 0.2$
 $= 0.3\text{ kg m s}^{-1}$
- 8 B $v^2 = u^2 + 2as$
 $100^2 = 0 + 2(4)(s)$
 $s = 1250\text{m}$
- 9 C Daripada persamaan $\frac{mv^2}{r} = \frac{GMm}{r^2}$, daya memusat, $F = \frac{mv^2}{r}$ adalah sama dengan daya graviti antara Bumi dan satelit, $F = \frac{GMm}{r^2}$
From the equation $\frac{mv^2}{r} = \frac{GMm}{r^2}$, centripetal force, $F = \frac{mv^2}{r}$ is equal to the gravitational force between the Earth and the satellite, $F = \frac{GMm}{r^2}$

- 10 D** Ciri-ciri satelit Geopegun; Arah gerakan sama dengan arah putaran Bumi, tempoh orbit sama dengan tempoh putaran Bumi iaitu 24 jam, berada di atas kedudukan geografi/lokasi yang sama pada permukaan Bumi.
Characteristics of Geostationary satellite; Direction of motion same as the direction of rotation of Earth, orbital period equal to period of rotation of Earth, which is 24 hours, above the same geographical position/location on the surface of the Earth.
- 11 B** Termometer mengaplikasikan prinsip keseimbangan terma. Apabila keseimbangan terma dicapai pemindahan haba bersih antara pesakit dan termometer adalah sifar dan suhu badan pesakit adalah sama dengan bacaan suhu termometer.
Thermometer applied the principle of thermal equilibrium. When thermal equilibrium is achieved the net heat transfer between the patient and the thermometer is zero and the temperature of the patient is equal to the temperature reading of the thermometer.
- 12 B** Air mendidih menyerap haba pendam pengewapan dan bertukar menjadi stim. Apabila stim terkondensasi pada permukaan pakaian, haba pendam tentu yang tinggi dibebaskan dan membantu menghilangkan kedutan pada pakaian dengan lebih cepat dan efisien.
Boiling water absorbs latent heat of vaporisation and changes to steam. When the steam condenses on clothes, large amount of latent heat is released onto the clothes which helps to remove wrinkles faster and more efficient.
- 13 A** Hukum Charles menyatakan bahawa isi padu adalah berkadar terus dengan suhu mutlak bagi suatu gas berjisim tetap pada tekanan malar. Air panas mempunyai suhu yang tinggi maka isi padu bola ping pong bertambah.
Charles' law states that volume is directly proportional to absolute temperature for a fixed mass gas at constant temperature. Hot water has a high temperature thus the volume of the ping pong ball increases.
- 14 B** Pelembapan berlaku di mana amplitud ayunan kerusi goyang berkurang dengan masa kerana kehilangan tenaga secara beransur-ansur sehingga ayunan berhenti.
Damping occurs where amplitude of oscillation of the rocking chair decreases with time due to gradual loss of energy until the oscillation stops.
- 15 B** Inersia bertambah apabila jisim bertambah. Gelas yang berjisim besar mempunyai inersia yang lebih besar untuk mengekalkan keadaan asalnya iaitu pegun. Maka gelas tidak bergerak apabila alas meja disentak.
Inertia increases as mass increases. Glass with greater mass has a greater inertia to remain its original state at rest. Thus, the glass does not move when table cloth is pulled in a sudden.
- 16 A** Rumah yang tinggi membolehkan udara panas berada di atas, maka haba tidak terperangkap dalam rumah dan udara dalam rumah menjadi lebih sejuk.
A high house let the hot air to rise above, so no heat trap inside the house and the air in the house become cooler.
- 17 A** Busur 'bulbous' menghasilkan gelombang air berinterferens memusnah dengan gelombang air yang dihasilkan oleh busur kapal. Maka air di sekitar kapal menjadi lebih tenang dan mengurangkan geseran air yang menentang pergerakan kapal.
Bulbous bow produces water waves that destructive interference with the water waves produced by the bow of the ship. This makes the water around the ship calmer to reduce the water drag that oppose the motion of the ship.
- 18 D** Ciri-ciri gelombang terbias; Arah berubah, laju berubah, panjang gelombang berubah, frekuensi tetap.
Characteristics of refracted wave; Direction changes, speed changes, wavelength changes, frequency remain.
- 19 B**
- $$n = \frac{\sin i}{\sin r} \qquad 1.50238871 = \frac{1}{\sin c}$$
- $$n = \frac{\sin 60^\circ}{\sin 35.2^\circ} \qquad \sin c = 0.6656$$
- $$n = 1.50238871 \qquad c = 41.73^\circ$$
- $$n = \frac{1}{\sin c}$$

- 20 A Imej yang dihasilkan oleh kanta cembung bergantung kepada panjang fokus dan jarak objek dari kanta. Panjang fokus yang lebih panjang, jarak objek dari kanta yang lebih pendek menghasilkan imej yang lebih besar.
The image produced by a convex lens depends upon the focal length of the lens and the distance of the object from the lens. Longer focal length, shorter object distance produced bigger image.
- 21 D Kapal terbang mengalami pecutan sifar apabila kesemua daya yang bertindak ke atas kapal terbang berada dalam keseimbangan.
Aeroplane experiences zero acceleration when all forces acting on the aeroplane are in equilibrium.
- 22 C Apabila jisim bertambah, berat beban bertambah. Maka daya komponen beban yang ditunjukkan oleh neraca spring bertambah.
When mass increases, the weight of load increases. Thus the component forces of the load show by the spring balance increases.
- 23 A Hukum Hooke diaplikasikan pada spring.
Hooke's Law applied in a spring.
- 24 B Udara yang nipis di altitud tinggi menyebabkan tekanan atmosfera menjadi rendah.
Thin air at high altitudes causes the atmospheric pressure to be lower.
- 25 1 N
$$\frac{F_1}{A_1} = \frac{F_2}{A_2}$$
 [Tiada pilihan jawapan di kertas peperiksaan 2022]
[No answer choice in examination paper 2022]
$$\frac{F_1}{200 \times 10^{-4}} = \frac{100}{2}$$

$$F_1 = 1 \text{ N}$$
- 26 C Bagi jasad terapung, daya apungan sama dengan berat air disesarkan. Apabila berat kapal bertambah, daya apungan bertambah maka berat air disesarkan bertambah.
For floating body, the buoyant force is equal to the weight of water displaced. When weight of ship increases, buoyant force increases thus weight of water displaced increases.
- 27 A Prinsip Bernoulli menyatakan bahawa apabila halaju bendalir bertambah, tekanan bendalir berkurang. Halaju angin di hadapan garisan kuning adalah tinggi, menghasilkan kawasan bertekanan rendah. Angin di belakang garisan kuning lebih tenang (halaju rendah), menghasilkan kawasan bertekanan tinggi. Perbezaan tekanan menghasilkan daya yang bertindak dari kawasan bertekanan tinggi ke kawasan bertekanan rendah.
Bernoulli's principle states that when the velocity of fluid increases, the pressure in the fluid decreases. The velocity of wind in front of the yellow line is high, causes a low-pressure region. The wind behind the yellow line is calmer (low velocity), causes a high-pressure region. Difference in pressure produced force acting from a high-pressure region to low pressure region.
- 28 A Daripada graf V-I, rintangan diperoleh melalui kecerunan graf, di mana $R = \frac{V}{I}$
From V-I graph, resistance is determined from the gradient, where $R = \frac{V}{I}$
- 29 A Haba terhasil daripada elemen pemanas yang mempunyai rintangan yang tinggi. Rintangan elemen pemanas ditingkatkan dengan menggunakan dawai nikrom (rintangan tinggi), luas keratan rentas dawai kecil (dawai halus) dan dawai yang panjang.
Heat produced from high resistance heating element. Resistance in the heating element can be increased by using nichrome wire (high resistance), small cross-sectional area wire (finer wire) and longer wire.

- 30 D** Nilai rintangan dalam bagi sel kering yang disusun secara selari akan berkurang, $\frac{1}{r} = \frac{1}{r_1} + \frac{1}{r_2}$.
Mengikuti persamaan $\varepsilon = IR + Ir$, d.g.e. sel kering, ε yang disusun secara selari juga berkurang.
Value of internal resistance for dry cells arranged in parallel will be decreases, $\frac{1}{r} = \frac{1}{r_1} + \frac{1}{r_2}$.
According to equation $\varepsilon = IR + Ir$, e.m.f. dry cells, arranged in parallel also decreases.
- 31 D** Spesifikasi “240 V, 1500 W” bermaksud seterika stim menggunakan/melepaskan 1500 J tenaga elektrik dalam satu saat apabila disambungkan dengan bekalan kuasa/beroperasi pada 240 V.
Specification “240 V, 1500 W” means the iron steam use/dissipated 1500 J electrical energy in one second when connected to/operated at 240 V of power supply.
- 32 D** Medan lastik ialah medan magnet paduan yang dihasilkan oleh interaksi antara medan magnet daripada konduktor pembawa arus dengan medan magnet daripada magnet kekal. Medan lastik mengenakan satu daya paduan ke atas konduktor itu.
A catapult field is a resultant magnetic field produced by the interaction between the magnetic field from a current-carrying conductor and the magnetic field from a permanent magnet. The catapult field exerts a resultant force on the conductor.
- 33 A** Hukum Faraday menyatakan bahawa magnitud d.g.e. aruhan adalah berkadar terus dengan kadar pemotongan fluks magnet. Bagi gerakan relatif antara solenoid dengan magnet, d.g.e. aruhan bertambah apabila laju gerakan relatif bertambah (jarak antara magnet bar dan gegelung bertambah), bilangan lilitan solenoid bertambah, kekuatan medan magnet bertambah.
Faraday’s law states that the magnitude of induced e.m.f. is directly proportional to the rate of cutting of magnetic flux. For the relative motion of a solenoid and magnet, the induced e.m.f. increases when the speed of relative motion increases (distance between the bar magnet and the coil increases), the number of turns of the solenoid increases and the strength of the magnetic field increases.
- 34 D** Kaedah yang betul untuk mengurangkan kehilangan tenaga dalam sebuah transformer:
Method to reduce energy loss in a transformer:
1. Menggunakan dawai kuprum tebal (mengurangkan rintangan gegelung)
Using thick copper wire (reduce resistance of coil)
 2. Menggunakan teras besi berlamina (elak arus pusar)
Using a laminated iron core (prevent eddy current)
 3. Menggunakan teras besi lembut. (elak histerisis)
Using a soft iron core. (prevent hysteresis)
 4. Lilitkan gegelung sekunder di atas gegelung primer. (elak kebocoran fluks magnet)
Wind the secondary coil on top of primary coli. (prevent leakage of magnetic flux)
- 35 A** Rektifikasi gelombang separuh dengan voltan output diratakan oleh kapasitor.
Half-wave rectification with smoothen output voltage by a capacitor.
- 36 B** Apabila suis S dihidupkan, mentol P menyala dengan malap kerana perintang berintang tinggi* dan arus tapak, I_B adalah sangat kecil. Mentol Q menyala dengan terang kerana arus pengumpul, I_C adalah besar berbanding dengan arus tapak, I_B .
When switch S is turned on, bulb P is dim because resistor has a high resistance and the base current, I_B is very small. Bulb Q lights up very brightly because the collector current, I_C is large compared with the base current, I_B .*
- *Rintangan tinggi pada litar tapak untuk menghadkan arus tapak supaya transistor tidak menjadi panas dan terbakar.
**The resistance at the base circuit is large to limit the base current, I_B so that the transistor will not become too hot and burn.*

- 37 A** Perubahan nombor proton / *Change in proton number* = $92 - 92 = 0$
 Perubahan nombor nukleon / *Change in nucleon number* = $238 - 234 = 4$
 Sinaran radioaktif yang dibebaskan / *Radioactive rays released*: 1 alfa/alpha, 2 beta

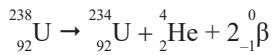

- 38 B** Pembelahan nukleus ialah tindak balas nuklear apabila satu nukleus yang berat membelah menjadi dua atau lebih nukleus yang lebih ringan dengan membebaskan tenaga yang banyak.
Nuclear fission is a nuclear reaction when a heavy nucleus splits into two or more lighter nuclei while releasing a large amount of energy.

- 39 D** Apabila suatu permukaan logam disinari oleh alur cahaya yang mempunyai frekuensi tertentu, elektron daripada logam itu dapat dipancar keluar. Fenomena ini dikenali sebagai kesan fotoelektrik.
When a metal surface is illuminated by a beam of light at a certain frequency, electrons can be emitted from the metal. This phenomenon is known as photoelectric effect.

- 40 C** Daripada persamaan Teori Fotoelektrik Einstein :

From equation of Einstein's Photoelectric Theory:

$$hf = W + \frac{1}{2} mv_{\text{maks}}^2$$

hf = tenaga foton / *photon energy*

f = frekuensi minimum foton cahaya yang menghasilkan kesan fotoelektrik
minimum frequency for a light photon to produce photoelectric effect

W = tenaga minimum yang diperlukan untuk membebaskan fotoelektron
minimum energy required to release a photoelectron

$\frac{1}{2} mv_{\text{maks}}^2$ = tenaga kinetik maksimum fotoelektron
maximum kinetic energy of a photoelectron

Bahagian A/Section A

Soalan Questions		Jawapan Answers	Sub markah Subs marks	Markah total Total marks
1	(a)	Kuantiti terbitan // Kuantiti vektor <i>Derived quantity // Vector quantity</i>	1	4
	(b)	(i) ✓ kedalaman rod tenggelam di dalam air, d <i>depth of rod immerse in water, d</i>	1	
		(ii) – Melukis garisan tegak dari 0.07 m hingga ke graf. <i>Draw vertical line from 0.07 m towards the graph.</i> – Menyatakan nilai F_B dengan betul iaitu 0.175. <i>State the value of F_B correctly which is 0.175.</i>	1 1	
2	(a)	Kesan fotoelektrik <i>Photoelectric effect</i>	1	4
	(b)	– Elektron ditarik ke anod <i>Electrons are attracted to anode</i> – Pergerakan elektron dari katod ke anod menghasilkan arus <i>Movement of electrons from cathode to anode produce current</i> – Kadar pengaliran cas ditunjukkan oleh pesongan penunjuk miliammeter <i>Rate of charge flow show by deflection of miliammeter pointer</i> (Mana-mana dua jawapan) <i>(Any two answers)</i>	1 1	

Soalan Questions		Jawapan Answers	Sub markah Subs marks	Markah total Total marks
	(c)	Penggantian / Substitution: $W = (6.63 \times 10^{-34})(5.2 \times 10^{14})$ Jawapan dengan unit yang betul / Answer with correct unit: $3.4476 \times 10^{-19} \text{J} // 3.4476 \times 10^{-19} \text{ N m} // 3.4476 \times 10^{-19} \text{ Js Hz}$	1 1	
3	(a) (i)	Masa untuk jisim/aktiviti/bilangan nukleus/keaktifan menjadi separuh. // Masa untuk separuh jisim/bilangan nukleus mereput. <i>Time for mass/activity/number of nucleus/nuclei to become half. // Time for half of mass/number of nucleus/nuclei to decay.</i>	1	
	(b)	<ul style="list-style-type: none"> – Melukis garis mengufuk dari 500 ke graf. <i>Draw a horizontal line from 500 to the graph.</i> – Menulis jawapan 3.2 minit. <i>Write the answer 3.2 minutes.</i> <p>Aktiviti (Bilangan per minit) <i>Activity (Count per minute)</i></p> <p style="text-align: right;">Masa (minit) <i>Time (minute)</i></p>	1 1	
	(c)	$N = \left(\frac{1}{2}\right)^n N_0$ $= \left(\frac{1}{2}\right)^4 1000$ $= 62.5 \text{ bilangan per minit/count per minute}$ <p>Atau/Or, 1000 → 500 → 250 → 125 → 62.5</p>	1 1	
(d)	Untuk menjadi lebih stabil // Nukleus tidak stabil <i>To become more stable // Unstable nuclei</i>	1	6	
4	(a)	Kedudukan geografi berubah // Orbit rendah/tinggi daripada orbit Bumi geopegun // Tempoh pendek/panjang daripada 24 jam // Tempoh orbit berbeza dengan tempoh putaran Bumi // Arah gerakan tidak perlu sama dengan arah putaran Bumi. <i>Changing geographical position // High/low orbit than geostationary Earth orbit // Period short/long than 24 hours // Orbital period different with period of rotation of Earth // Direction of motion need not be the same with the direction of Earth rotation.</i> (Mana-mana satu jawapan) <i>(Any one answer)</i>	1	

Soalan Questions		Jawapan Answers	Sub markah Subs marks	Markah total Total marks	
(b)	(i)	$v = \sqrt{\frac{GM}{R}}$ $= \sqrt{\frac{(6.67 \times 10^{-11})(5.97 \times 10^{24})}{(850 \times 10^3 + 6.37 \times 10^6)}}$ $= 7426.4538 \text{ m s}^{-1} // 7.426 \times 10^3 \text{ m s}^{-1} \text{ (min 3 t.p. / min 3 d.p.)}$	2 1		
	(ii)	$T = \sqrt{\frac{4\pi^2 r^3}{GM}}$ $= \sqrt{\frac{4\pi^2(850 \times 10^3 + 6.37 \times 10^6)^3}{(6.67 \times 10^{-11})(5.97 \times 10^{24})}}$ $= 6108.5141 \text{ s}$	1 1		
(c)		<ul style="list-style-type: none"> – Jatuh/turun ke orbit yang lebih rendah // Jejari orbit berkurang. <i>Fall to lower orbit // Orbital radius decreases.</i> – Jatuh dengan halaju tinggi // Jatuh dengan pecutan. <i>Fall with high velocity // Fall with acceleration.</i> – Kekuatan medan graviti bertambah. <i>Gravitational field strength increases.</i> – Rintangan/geseran/seretan udara bertambah // Suhu bertambah. <i>Air resistance/friction/drag increases // Temperature increases.</i> – Meletup // Terbakar // Menjana haba // Melanggar Bumi. <i>Explode // Burnt // Generate heat // Hit the Earth.</i> <p>(Mana-mana tiga jawapan) (Any three answers)</p>	1 1 1	9	
5	(a)	Frekuensi sama dan sefasa // Frekuensi sama dan beza fasa yang tetap. <i>Same frequency and in phase // Same frequency and constant phase different.</i>	1		
	(b)	(i)	Rajah 5.1 < Rajah 5.2 // sebaliknya. <i>Diagram 5.1 < Diagram 5.2 // vice versa.</i>		1
		(ii)	Rajah 5.1 > Rajah 5.2 // sebaliknya. <i>Diagram 5.1 > Diagram 5.2 // vice versa.</i>		1
		(iii)	Sama // Rajah 5.1 = Rajah 5.2 <i>Same // Diagram 5.1 = Diagram 5.2</i>		1
	(c)	(i)	a bertambah, X berkurang // Berkadar songsang. <i>a increases, X decreases // Inversely proportional.</i>		1
		(ii)	Interferens <i>Interference</i>		1
	(d)	(i)	Gantian yang betul / Correct substitution: $1.8 = \frac{(3)(X)}{10}$		1
Jawapan dengan unit yang betul / Answer with correct unit: X = 6 cm			1		
(ii)		Berkurang <i>Decreases</i>	1		
6	(a)	Daya graviti yang bertindak ke atas jasad. <i>Gravitational force acting on a body.</i>	1		

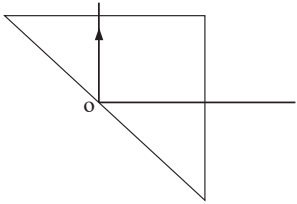
Soalan Questions		Jawapan Answers	Sub markah Subs marks	Markah total Total marks
	(b) (i)	Daya apungan sama dengan jumlah berat kayak dan atlet. <i>The buoyant force is equal to the total weight of the kayak and the athlete.</i>	1	9
	(ii)	Gantian yang betul / Correct substitution: $F_B = \rho Vg$ $1100 = (1000)(V)(9.81)$ Jawapan dengan betul / Correct answer: $V = 0.1121$ (min 3 t.p. / min 3 d.p.)	1	
	(c) (i)	Kayak P // Kayak atlet X <i>Kayak P // Athlete X's kayak</i>	1	
	(ii)	Kayak P // Kayak atlet X <i>Kayak P // Athlete X's kayak</i>	1	
	(iii)	Kayak P // Kayak atlet X <i>Kayak P // Athlete X's kayak</i>	1	
	(d) (i)	Berat beban bertambah, isi padu air yang tersesar bertambah // Berkadar terus. <i>The weight of the load increases, the volume of water displaced increases // Directly proportional.</i>	1	
	(ii)	Berat beban bertambah, daya apungan bertambah // Berkadar terus. <i>The weight of the load increases, the buoyant force increases // Directly proportional.</i>	1	
7	(a)	Nisbah laju cahaya dalam vakum kepada laju cahaya dalam medium // Nisbah sin sudut tuju kepada sin sudut biasan. <i>Ratio of speed of light in vacuum to the speed of light in medium // Ratio of sin of incident angle to the sin of refractive angle</i>	1	9
	(b) (i)	Gantian yang betul / Correct substitution: $n = \frac{1}{\sin c}$ $1.49 = \frac{1}{\sin c}$ Jawapan dengan unit yang betul / Answer with correct unit: $c = 42.155^\circ$	1	
	(ii)		1	
	(c) (i)	– Panjang fokus lebih/panjang. <i>Focal length more/longer.</i>	1	
		– Imej tajam // Imej jelas. <i>Sharp image // Clear image</i>	1	
	(ii)	– Diameter kanta lebih panjang. <i>Diameter of lense more longer.</i>	1	
		– Imej tajam // Imej jelas. <i>Sharp image // Clear image</i>	1	
	(d)	Kanta P <i>Lens P</i>	1	9

Soalan Questions		Jawapan Answers	Sub markah Subs marks	Markah total Total marks	
8	(a)	Rektifikasi gelombang separuh. <i>Half-wave rectification</i>	1		
	(b)	– Beza keupayaan meningkat, kapasitor dicas/tenaga disimpan dalam kapasitor. <i>Potential difference increase, capacitor charged/energy stored in capacitor.</i>	1		
		– Beza keupayaan menyusut, kapasitor dinyahcas / tenaga dikembalikan ke dalam litar. <i>Potential difference decrease, capacitor discharged/energy released in circuit.</i>	1		
		– Voltan output dirata // Arus rata. <i>Smooth output voltage // Smooth current.</i> (Mana-mana dua jawapan) (Any two answers)			
	(c)	(i)	– 4 – Rektifikasi gelombang penuh. <i>Full-wave rectification</i>		1 1
		(ii)	– Tinggi <i>High</i> – Arus rata/licin // Voltan output rata // Simpan banyak cas/tenaga. <i>Smooth current // Smooth output voltage // Store more charge /energy.</i>		1 1
(d)	Gantian yang betul / Correct substitution: $\frac{N_s}{N_p} = \frac{V_s}{V_p}$ $\frac{N_s}{N_p} = \frac{12}{240}$ $\frac{N_s}{N_p} = \frac{1}{20}$ Jawapan yang betul / Correct answer: $N_p:N_s = 20 : 1$	1 1	9		

Bahagian B/Section B

Soalan Questions		Jawapan Answers	Sub markah Subs marks	Markah total Total marks	
9	(a)	Penghasilan d.g.e. aruhan daripada gerakan relatif antara konduktor dengan medan magnet atau apabila konduktor itu berada di dalam medan magnet yang berubah. <i>Production of an induced e.m.f. from relative motion between the conductor and a magnetic field or when the conductor is in a changing magnetic field</i>	1		
	(b)	(i)	X – Utara / North // U / N Y – Selatan / South // S		1 1
		(ii)	Menyatakan arah aliran arus dengan betul : <i>State direction of flow of current correctly:</i> Arus dari A ke B // Arus ke kanan. <i>Current from A to B // Current to the right.</i> Menentukan arah pesongan penunjuk galvanometer yang betul: <i>Determine the deflection of galvanometer pointer correctly:</i> Pesong ke kiri/A. <i>Deflects to the left/A.</i>		1 1
		(iii)	– Menentang utara/N // Hukum Lenz. <i>Oppose North/N // Lenz law.</i> – Ada d.g.e. // Ada arus // Pematongan/perubahan fluks/medan magnet. <i>Has e.m.f. // Has current // Cutting/change of magnetic flux/field.</i> (Mana-mana sat jawapan) <i>(Any one answer)</i>		1
	(c)	– Gerakan relatif antara konduktor/gegelung/solenoid dan medan magnet. <i>Relative motion between conductor/coil/solenoid and magnetic field.</i> – Medan magnet terpotong // Perubahan fluks/medan magnet. <i>Cutting of magnetic field // Changing magnetic flux/field.</i> – D.g.e. teraruh/terhasil. <i>E.m.f. induced/produced.</i> – Mematuhi Hukum Lenz. <i>Obey Lenz's Law.</i> – Arah arus aruhan sentiasa menentang perubahan fluks yang menghasilkannya. <i>Induced current always oppose change of flux producing it.</i> (Mana-mana empat jawapan) <i>(Any four answers)</i>	1 1 1 1		

Soalan Questions		Jawapan Answers	Sub markah Subs marks	Markah total Total marks												
(d)		<table border="1"> <thead> <tr> <th>Ciri-ciri Characteristics</th> <th>Sebab Reason</th> </tr> </thead> <tbody> <tr> <td>Jenis bekalan kuasa: Arus ulang alik <i>Type of power supply: Alternating current</i></td> <td>Medan magnet berubah // Pemotongan fluks/medan magnet. <i>Changing/cutting of magnetic flux/field.</i></td> </tr> <tr> <td>Bahan permukaan dapur: Seramik <i>Material for surface of cooker: Ceramic</i></td> <td>Muatan haba tentu tinggi // Tidak panas // Kenaikan suhu rendah // Penebat. <i>High specific heat capacity // Not hot // Low rise in temperature // Insulator.</i></td> </tr> <tr> <td>Bahan dasar periuk: Besi <i>Material for base of pot: Iron</i></td> <td>Ada arus pusar // Wujud aruhan elektromagnet // Hasil d.g.e. <i>Form eddy current // Form induced current // Form e.m.f.</i></td> </tr> <tr> <td>Jenis gegelung elektromagnet: Kuprum <i>Type of electromagnetic coil: Copper</i></td> <td>Rintangan rendah // Kerintangan rendah // Hasil banyak arus // Medan magnet kuat. <i>Low resistance // Low resistivity // Produce more current // Stronger magnetic field.</i></td> </tr> <tr> <td>Dapur aruhan L dipilih. <i>Induction cooker L is chosen.</i></td> <td>Menggunakan arus ulang alik, bahan permukaan dapur seramik, bahan dasar periuk besi, jenis gegelung elektromagnet kuprum. <i>Use alternating current, material for surface cooker metallic, material for base of pot iron and type of electromagnetic coil copper.</i></td> </tr> </tbody> </table>	Ciri-ciri Characteristics	Sebab Reason	Jenis bekalan kuasa: Arus ulang alik <i>Type of power supply: Alternating current</i>	Medan magnet berubah // Pemotongan fluks/medan magnet. <i>Changing/cutting of magnetic flux/field.</i>	Bahan permukaan dapur: Seramik <i>Material for surface of cooker: Ceramic</i>	Muatan haba tentu tinggi // Tidak panas // Kenaikan suhu rendah // Penebat. <i>High specific heat capacity // Not hot // Low rise in temperature // Insulator.</i>	Bahan dasar periuk: Besi <i>Material for base of pot: Iron</i>	Ada arus pusar // Wujud aruhan elektromagnet // Hasil d.g.e. <i>Form eddy current // Form induced current // Form e.m.f.</i>	Jenis gegelung elektromagnet: Kuprum <i>Type of electromagnetic coil: Copper</i>	Rintangan rendah // Kerintangan rendah // Hasil banyak arus // Medan magnet kuat. <i>Low resistance // Low resistivity // Produce more current // Stronger magnetic field.</i>	Dapur aruhan L dipilih. <i>Induction cooker L is chosen.</i>	Menggunakan arus ulang alik, bahan permukaan dapur seramik, bahan dasar periuk besi, jenis gegelung elektromagnet kuprum. <i>Use alternating current, material for surface cooker metallic, material for base of pot iron and type of electromagnetic coil copper.</i>	1+1	20
	Ciri-ciri Characteristics	Sebab Reason														
	Jenis bekalan kuasa: Arus ulang alik <i>Type of power supply: Alternating current</i>	Medan magnet berubah // Pemotongan fluks/medan magnet. <i>Changing/cutting of magnetic flux/field.</i>														
	Bahan permukaan dapur: Seramik <i>Material for surface of cooker: Ceramic</i>	Muatan haba tentu tinggi // Tidak panas // Kenaikan suhu rendah // Penebat. <i>High specific heat capacity // Not hot // Low rise in temperature // Insulator.</i>														
	Bahan dasar periuk: Besi <i>Material for base of pot: Iron</i>	Ada arus pusar // Wujud aruhan elektromagnet // Hasil d.g.e. <i>Form eddy current // Form induced current // Form e.m.f.</i>														
	Jenis gegelung elektromagnet: Kuprum <i>Type of electromagnetic coil: Copper</i>	Rintangan rendah // Kerintangan rendah // Hasil banyak arus // Medan magnet kuat. <i>Low resistance // Low resistivity // Produce more current // Stronger magnetic field.</i>														
Dapur aruhan L dipilih. <i>Induction cooker L is chosen.</i>	Menggunakan arus ulang alik, bahan permukaan dapur seramik, bahan dasar periuk besi, jenis gegelung elektromagnet kuprum. <i>Use alternating current, material for surface cooker metallic, material for base of pot iron and type of electromagnetic coil copper.</i>															
		1+1														
		1+1														
		1+1														
		1+1														
		1+1														
10	(a)	(i) Mengukur beza keupayaan/voltan/d.g.e. <i>Measure potential difference/voltage/e.m.f.</i>	1													
	(b)	(i) – Ammeter tunjuk/ada bacaan // Bacaan ammeter bertambah // Jarum/penunjuk ammeter terpesong. <i>Ammeter shows/has reading // Ammeter reading increases // Needle/pointer of ammeter deflects.</i>	1													
			– Bacaan voltmeter berkurang. <i>Voltmeter reading decreases.</i>	1												
		(ii) – Arus/cas/elektron mengalir // Beza keupayaan/voltan merentasi mentol. <i>Current/charge/electron flow // Potential difference/voltage across bulb.</i>	1													
		– Mengatasi rintangan dalam sel // Voltan susut apabila litar lengkap. <i>Overcome internal resistance of cell // Voltage drop when circuit complete.</i>	1													

Soalan Questions		Jawapan Answers	Sub markah Subs marks	Markah total Total marks										
(c)		<table border="1"> <thead> <tr> <th>Ciri-ciri Characteristics</th> <th>Sebab Reason</th> </tr> </thead> <tbody> <tr> <td>Jenis sumber cahaya: Diod pemancar cahaya // Mentol LED // LED <i>Source of light: Light emitting diode // LED bulb // LED</i></td> <td>Kehilangan tenaga/kuasa rendah // Kurang haba // Kecekapan tinggi // Keamatan tinggi. <i>Low energy/power loss // Less heat // High efficiency // High intensity.</i></td> </tr> <tr> <td>Sambungan sumber cahaya: Selari (terima lukisan) <i>Connection of light source: Parallel (accept drawing)</i></td> <td>Rintangan berkesan kecil // Arus besar // Satu mentol rosak yang lain masih berfungsi. <i>Small effective resistance // More current // One bulb blow others still function.</i></td> </tr> <tr> <td>Ciri wayar penyambung: Dawai kerintangan rendah <i>Characteristic of connecting wire: Low resistivity wire</i></td> <td>Rintangan rendah // Kecekapan tinggi // Banyak arus // Kehilangan kuasa/tenaga rendah // Kehilangan haba rendah. <i>Low resistance // High efficiency // More current // Less power/energy loss // Less heat loss.</i></td> </tr> <tr> <td>Sambungan sel kering <i>Connection of dry cells:</i> Alt.1- Sel kering sesiri // Jenis I // Sambungan I <i>Alt.1- Dry cells in series // Type I // Connection I</i> Alt.2- Sel kering selari // Jenis II // Sambungan II // Sel kering gabungan // Sel kering selari dan sesiri <i>Alt.2- Dry cells in parallel // Type II // Connection II // Dry cells combination // Dry cells parallel and series</i></td> <td>Alt.1- Voltan tinggi // d.g.e. tinggi // Keamatan tinggi // Kuasa tinggi // Tenaga tinggi. <i>Alt.1 – High voltage // High e.m.f. // High intensity // High power // High energy.</i> Alt.2- Jumlah rintangan dalam berkurang // Arus tinggi // Keamatan tinggi // Kuasa tinggi // Tenaga tinggi. <i>Alt.2- Total internal resistance small // High current // High intensity // High power // High energy.</i></td> </tr> </tbody> </table>	Ciri-ciri Characteristics	Sebab Reason	Jenis sumber cahaya: Diod pemancar cahaya // Mentol LED // LED <i>Source of light: Light emitting diode // LED bulb // LED</i>	Kehilangan tenaga/kuasa rendah // Kurang haba // Kecekapan tinggi // Keamatan tinggi. <i>Low energy/power loss // Less heat // High efficiency // High intensity.</i>	Sambungan sumber cahaya: Selari (terima lukisan) <i>Connection of light source: Parallel (accept drawing)</i>	Rintangan berkesan kecil // Arus besar // Satu mentol rosak yang lain masih berfungsi. <i>Small effective resistance // More current // One bulb blow others still function.</i>	Ciri wayar penyambung: Dawai kerintangan rendah <i>Characteristic of connecting wire: Low resistivity wire</i>	Rintangan rendah // Kecekapan tinggi // Banyak arus // Kehilangan kuasa/tenaga rendah // Kehilangan haba rendah. <i>Low resistance // High efficiency // More current // Less power/energy loss // Less heat loss.</i>	Sambungan sel kering <i>Connection of dry cells:</i> Alt.1- Sel kering sesiri // Jenis I // Sambungan I <i>Alt.1- Dry cells in series // Type I // Connection I</i> Alt.2- Sel kering selari // Jenis II // Sambungan II // Sel kering gabungan // Sel kering selari dan sesiri <i>Alt.2- Dry cells in parallel // Type II // Connection II // Dry cells combination // Dry cells parallel and series</i>	Alt.1- Voltan tinggi // d.g.e. tinggi // Keamatan tinggi // Kuasa tinggi // Tenaga tinggi. <i>Alt.1 – High voltage // High e.m.f. // High intensity // High power // High energy.</i> Alt.2- Jumlah rintangan dalam berkurang // Arus tinggi // Keamatan tinggi // Kuasa tinggi // Tenaga tinggi. <i>Alt.2- Total internal resistance small // High current // High intensity // High power // High energy.</i>	1+1	
	Ciri-ciri Characteristics	Sebab Reason												
	Jenis sumber cahaya: Diod pemancar cahaya // Mentol LED // LED <i>Source of light: Light emitting diode // LED bulb // LED</i>	Kehilangan tenaga/kuasa rendah // Kurang haba // Kecekapan tinggi // Keamatan tinggi. <i>Low energy/power loss // Less heat // High efficiency // High intensity.</i>												
	Sambungan sumber cahaya: Selari (terima lukisan) <i>Connection of light source: Parallel (accept drawing)</i>	Rintangan berkesan kecil // Arus besar // Satu mentol rosak yang lain masih berfungsi. <i>Small effective resistance // More current // One bulb blow others still function.</i>												
	Ciri wayar penyambung: Dawai kerintangan rendah <i>Characteristic of connecting wire: Low resistivity wire</i>	Rintangan rendah // Kecekapan tinggi // Banyak arus // Kehilangan kuasa/tenaga rendah // Kehilangan haba rendah. <i>Low resistance // High efficiency // More current // Less power/energy loss // Less heat loss.</i>												
Sambungan sel kering <i>Connection of dry cells:</i> Alt.1- Sel kering sesiri // Jenis I // Sambungan I <i>Alt.1- Dry cells in series // Type I // Connection I</i> Alt.2- Sel kering selari // Jenis II // Sambungan II // Sel kering gabungan // Sel kering selari dan sesiri <i>Alt.2- Dry cells in parallel // Type II // Connection II // Dry cells combination // Dry cells parallel and series</i>	Alt.1- Voltan tinggi // d.g.e. tinggi // Keamatan tinggi // Kuasa tinggi // Tenaga tinggi. <i>Alt.1 – High voltage // High e.m.f. // High intensity // High power // High energy.</i> Alt.2- Jumlah rintangan dalam berkurang // Arus tinggi // Keamatan tinggi // Kuasa tinggi // Tenaga tinggi. <i>Alt.2- Total internal resistance small // High current // High intensity // High power // High energy.</i>													
		1+1												
		1+1												
		1+1												
		1+1												
(ii)	Litar R dipilih. <i>Circuit R is chosen.</i> Jenis sumber cahaya LED, sambungan sumber cahaya selari, wayar penyambung kerintangan rendah, sel kering (Alt.1 // Alt.2) <i>Source of light LED, connection of light source parallel, low resistivity connecting wire, dry cells (Alt.1 // Alt.2).</i>		2											
(d)	(i) Gantian yang betul / Correct substitution: $\frac{1}{r} = \frac{1}{r_1} + \frac{1}{r_2}$ $\frac{1}{r} = \frac{1}{0.5} + \frac{1}{0.5}$ Jawapan yang betul / Correct answer: $r = 0.25 \Omega$		1											
			1											

Soalan Questions		Jawapan Answers	Sub markah Subs marks	Markah total Total marks
	(ii)	<p>Rintangan berkesan yang betul / Correct effective resistance: $R = 60 + 0.25$ $= 60.25 \Omega$</p> <p>Gantian yang betul / Correct substitution: $\varepsilon = I(R + r)$ $9 = I(60.25)$</p> <p>Jawapan dengan unit yang betul / Answer with correct unit: $I = 0.149 \text{ A (min 3 t.p. / min 3 d.p.)}$</p>	1 1 1	20

Bahagian C/Section C

Soalan Questions		Jawapan Answers	Sub markah Subs marks	Markah total Total marks	
11	(a)	Darjah kepanasan. <i>Degree of hotness.</i>	1		
	(b)	(i)	<p>– Suhu awal 11.1(a) = 11.1(b) // Suhu awal sama. <i>Initial temperature 11.1(a) = 11.1(b) // Initial temperature same /equal.</i></p> <p>– Jisim 11.1(a) > 11.1(b) // Sebaliknya. <i>Mass 11.1(a) = 11.1(b) // Vice versa.</i></p>		1 1
		(ii)	– Kenaikan suhu 11.2(b) > 11.2(a) // Sebaliknya. <i>Rise in temperature 11.2(b) > 11.2(a) // Vice versa.</i>		1
		(iii)	<p>– Jisim bertambah, kenaikan suhu berkurang // Jisim berkadar songsang dengan kenaikan suhu. <i>Mass increases, rise in temperature decreases // Mass is inversely proportional to rise in temperature.</i></p> <p>– Muatan haba tentu malar // Haba malar // Masa dan kuasa malar. <i>Specific heat capacity constant // Heat constant // Time and power constant.</i></p>		1 1
	(c)		– Muatan haba tentu pasir rendah // Muatan haba tentu air laut tinggi <i>Specific heat capacity of sand lower // Specific heat capacity of sea water large/high</i>		1
			– Tenaga sama // Haba sama. <i>Energy same // Heat same.</i>		1
			– $Q = mc\theta$		1
	– Muatan haba tentu berkadar songsang dengan kenaikan suhu. <i>Specific heat capacity is inversely proportional to rise in temperature.</i>	1			
	– Kenaikan suhu pasir tinggi // Kenaikan suhu air laut rendah. <i>Rise in temperature of sand high // Rise in temperature of sea water low.</i>				
	(Mana-mana empat jawapan) <i>(Any four answers)</i>				

Soalan Questions		Jawapan Answers	Sub markah Subs marks	Markah total Total marks
(d)		<p>Cadangan Suggestions</p>	<p>Sebab Reason</p>	
		Muatan haba tentu dinding: Tinggi <i>Specific heat capacity of wall: High</i>	Kenaikan suhu rendah // Penebat. <i>Low rise in temperature // Insulator.</i>	1 + 1
		Muatan haba tentu bumbung: Tinggi <i>Specific heat capacity of roof: High</i>	Kenaikan suhu rendah // Penebat. <i>Low rise in temperature // Insulator.</i>	1 + 1
		Bahan dinding: Konkrit/Simen // Batu-bata // Kayu // Tanah liat // Berpenibat <i>Material of wall: Concrete/Cement // Brick// Wood // Clay // Insulated</i>	Pengaliran haba rendah // Kurang kekondusian haba // Kurang serap haba // Muatan haba tentu tinggi. <i>Low heat flow // Low heat conduction // Less heat absorb // High specific heat capacity.</i>	1 + 1
		Bahan bumbung: Seramik // Styrofoam // Asbestos // Batu-bata // Rumbia // Konkrit // Polimer // Berlapis // Berpenibat <i>Material of roof: Ceramic // Styrofoam // Asbestos // Brick // Concrete // Polymer // Layered // Insulated</i>	Pengaliran haba rendah // Kurang kekondusian haba // Kurang serap haba // Muatan haba tentu tinggi. <i>Low heat flow // Low heat conduction // Less heat absorb // High specific heat capacity.</i>	1 + 1
		Banyak tingkap <i>More/many windows</i>	Haba tidak terperangkap // Banyak udara masuk/keluar // Meningkatkan perolakan // Haba dibebaskan // Peredaran udara lebih baik. <i>Heat not trapped // More air in/ out // Increase convection // Hot air released // Better air flow.</i>	1 + 1
		Tingkap besar <i>Large window</i>	Haba tidak terperangkap // Banyak udara masuk/keluar // Meningkatkan perolakan // Haba dibebaskan // Peredaran udara lebih baik. <i>Heat not trapped // More air in/ out // Increase convection // Hot air released // Better air flow.</i>	1 + 1
		Lubang udara <i>Air hole</i>	Haba tidak terperangkap // Banyak udara masuk/keluar // Meningkatkan perolakan // Haba dibebaskan // Peredaran udara lebih baik. <i>Heat not trapped // More air in/ out // Increase convection // Hot air released // Better air flow.</i>	1 + 1

Soalan Questions			Jawapan Answers	Sub markah Subs marks	Markah total Total marks						
			<table border="1"> <thead> <tr> <th>Cadangan Suggestions</th> <th>Sebab Reason</th> </tr> </thead> <tbody> <tr> <td>Bumbung tinggi // Siling tinggi <i>High roof // High ceiling</i></td> <td>Haba tidak terperangkap // Udara dalam rumah sejuk // Udara panas di atas / Haba dibebaskan. <i>Heat not trapped // Cool air in house // Hot air above // Heat released.</i></td> </tr> <tr> <td>Tingkap berlapis // Tingkap kalis panas <i>Layered window // Hot proof window</i></td> <td>Kurang haba masuk // Kurang konduksi haba // Tidak serap haba. <i>Less heat in // Less heat conduction // Not absorb heat.</i></td> </tr> </tbody> </table>	Cadangan Suggestions	Sebab Reason	Bumbung tinggi // Siling tinggi <i>High roof // High ceiling</i>	Haba tidak terperangkap // Udara dalam rumah sejuk // Udara panas di atas / Haba dibebaskan. <i>Heat not trapped // Cool air in house // Hot air above // Heat released.</i>	Tingkap berlapis // Tingkap kalis panas <i>Layered window // Hot proof window</i>	Kurang haba masuk // Kurang konduksi haba // Tidak serap haba. <i>Less heat in // Less heat conduction // Not absorb heat.</i>	1+1	20
Cadangan Suggestions	Sebab Reason										
Bumbung tinggi // Siling tinggi <i>High roof // High ceiling</i>	Haba tidak terperangkap // Udara dalam rumah sejuk // Udara panas di atas / Haba dibebaskan. <i>Heat not trapped // Cool air in house // Hot air above // Heat released.</i>										
Tingkap berlapis // Tingkap kalis panas <i>Layered window // Hot proof window</i>	Kurang haba masuk // Kurang konduksi haba // Tidak serap haba. <i>Less heat in // Less heat conduction // Not absorb heat.</i>										
			1+1								
			(max. 10)								

KERTAS MODEL SIJIL PELAJARAN MALAYSIA 2023 SET 1

Kertas 1 / Paper 1

- 1 **C** Silinder penyukat digunakan untuk mengukur isi padu.
Measuring cylinder is used to measure volume.
- 2 **B** Jisim, laju, suhu dan masa adalah kuantiti skalar (mempunyai magnitud sahaja).
Mass, speed, temperature and time are scalar quantities (have magnitude only).
- 3 **D** Graf garis lurus dengan pintasan-y menunjukkan V (pemboleh ubah bergerak balas) bertambah secara linear dengan T (pemboleh ubah dimanipulasi).
Straight line graph with y-intercept shows V (responding variable) is increasing linearly with T (manipulated variable).
- 4 **C** Kedua-dua bola jatuh dengan pecutan graviti, $g = 9.81 \text{ m s}^{-2}$.
Both balls fall with gravitational acceleration, $g = 9.81 \text{ m s}^{-2}$.
- 5 **A** 0 – 5 s: Objek bergerak dengan halaju seragam.
Object moves with uniform velocity.
5 – 10 s: Objek pegun.
Objek is at rest.
- 6 **A**

$$m_1 u_1 + m_2 u_2 = (m_1 + m_2)v$$

$$(8\ 000)(20) + (1\ 000)(0) = (8\ 000 + 1\ 000)v$$

$$v = 17.78 \text{ m s}^{-1}$$
- 7 **C** Beg udara berfungsi untuk memanjangkan masa hentaman agar daya impuls dikurangkan.
Airbag is used to lengthen the time of impact hence reduce impulsive force.
- 8 **A**

$$F = \frac{mv^2}{R}$$

$$= \frac{(2)(5^2)}{2}$$

$$= 25 \text{ N}$$

- 9 D** Halaju planet dalam sistem suria paling tinggi apabila paling hampir dengan Matahari.
Velocity of planet in the Solar System is the highest when it is closest to the Sun.
- 10 B** Hukum Kepler Ketiga menyatakan bahawa kuasa dua tempoh orbit planet berkadar terus dengan kuasa tiga jejari orbit planet tersebut, $T^2 \propto r^3$.
Kepler's Third Law states that the square of the period of a planet is directly proportional to the cube of the radius of its orbit, $T^2 \propto r^3$.
- 11 C** Termometer mengaplikasikan prinsip keseimbangan terma. Bacaan suhu termometer sama dengan suhu badan pesakit.
Thermometer applied heat equilibrium. Temperature reading of thermometer equal to the patient's body temperature.
- 12 A** Daripada persamaan $\theta = \frac{Q}{mc}$, apabila haba dibekalkan dan jisim blok adalah sama, blok yang mempunyai muatan haba tentu paling rendah mengalami peningkatan suhu paling tinggi.
From equation $\theta = \frac{Q}{mc}$, when heat supplied and mass of blocks are equal, block with lowest specific high capacity will have a higher temperature rise.
- 13 B**
- $$Q_1 = Q_2$$
- $$m_1 c \theta_1 = m_2 c \theta_2$$
- $$(5)(50) = (8)(\theta_2)$$
- $$\theta_2 = 31.25^\circ\text{C}$$
- 14 B** Bagi gas berjisim dan bertekanan tetap, isi padu bertambah apabila suhu bertambah. Suhu bertambah kerana tenaga kinetik purata molekul bertambah apabila menerima haba daripada Matahari.
For a gas with fixed mass and pressure, the volume of the gas increases when its temperature increases. The increasing in temperature is due to the increasing of the average kinetic energy of the molecules when heat is supplied by the Sun.
- 15 A** Semasa pelembapan, gelombang kehilangan tenaga maka amplitud gelombang berkurang.
Waves loss energy during damping causes the amplitude to decrease.
- 16 B**
- $$\frac{v_1}{\lambda_1} = \frac{v_2}{\lambda_2}$$
- $$\frac{v_1}{6} = \frac{18}{9}$$
- $$v_1 = 12 \text{ cm s}^{-1}$$
- 17 D** Corak interferens gelombang cahaya mempunyai jarak yang tetap antara pinggir cerah dan pinggir gelap.
Interference pattern of light waves have a uniform distance between bright and dark fringes.
- 18 D** Sudut tuju ialah sudut di antara sinar tuju dan garis normal, manakala sudut biasan ialah sudut di antara sinar biasan dan garis normal.
Angle of incidence is the angle between the incident ray and the normal, whereas angle of refraction is the angle between refracted ray and the normal.
- 19 B** Prisma dalam binokular mengaplikasikan pantulan dalam penuh apabila sinar cahaya melaluinya.
Prisms in binocular applies total internal reflection when light rays pass through them.
- 20 C** Sinar cahaya yang melalui kanta cekung akan dibiaskan (mencapah) melalui titik fokus di hadapan kanta. Sinar cahaya yang melalui pusat optik kanta tidak mengalami pembiasan.
Light rays that pass through a concave lens will be refracted (diverged) from the focal point at the front of the lens. Light rays that pass through the optical centre does not experience refraction.

21 B Motosikal yang sedang memecut mempunyai daya bersih ke hadapan (arah pecutan).
A motorcycle which accelerates has a forward resultant/net force (in the direction of the acceleration).

22 C Daya mengufuk / *Horizontal force;*

$$F_x = 85 \cos 40^\circ \\ = 65.11 \text{ N}$$

23 C Guna kaedah segi tiga daya / *Use triangle of forces method.*

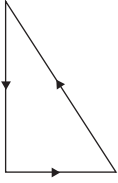

24 A Paras merkuri dalam turus yang disambungkan ke bekalan gas lebih rendah berbanding paras merkuri pada turus terbuka menunjukkan tekanan gas lebih tinggi (menekan merkuri ke bawah) berbanding atmosfera
Mercury level in a column connected to the gas supply is lower compared to that in an open column shows that the gas pressure is higher (push the mercury downwards) compared to atmospheric pressure.

25 A $F_B = \rho Vg$
 $6 = (2\,400)(V)(9.81)$
 $V = 2.548 \times 10^{-4} \text{ m}^3$

26 B Angin yang ditiup di antara kedua-dua bola ping pong mempunyai halaju yang tinggi mewujudkan kawasan bertekanan rendah. Tekanan yang lebih tinggi masing-masing di kiri dan kanan bola ping pong menolak kedua-dua bola ping pong mendekati satu sama lain.

Blown air in between two ping pong balls have high velocity. This creates a low-pressure region. High pressure from the left and right of the ping pong balls respectively pushed the two ping pong balls towards each other.

27 C $Q = It$
 $= (0.45)(30 \times 60)$
 $= 810 \text{ C}$

28 B Dalam litar elektrik, ammeter disambungkan secara sesiri dengan konduktor, manakala voltmeter dipasang secara selari dengan konduktor.

In an electric circuit, ammeter is connected in series with a conductor, while voltmeter is connected in parallel with a conductor.

29 A Filamen bergelung mempunyai panjang yang tinggi, maka rintangan dalam filamen bertambah.

Coiled shape filament has a longer wire, this increase the resistance in the filament.

30 D $E = Pt$
 $= (2.0)(8)$
 $= 16 \text{ kWj / kWh}$

Unit elektrik (kWj) / *Unit of electricity (kWh)* = $16 \text{ kWj / kWh} \times 31 \text{ hari/days}$
 $= 496 \text{ kWj / kWh (496 unit/units)}$

Kos elektrik/*Electric cost* = $(200 \times \text{RM}0.22) + (296 \times \text{RM}0.26)$
 $= \text{RM}120.96$

31 A Guna peraturan Tangan Kiri Fleming untuk tentukan arah daya pada kedua-dua belah gegelung.

Use Fleming's Left-Hand rule to determine direction of forces acting on both coils.

32 D Tenaga elektrik dipindahkan pada voltan tinggi agar arus yang mengalir direndahkan, maka kehilangan kuasa semasa penghantaran berkurang. ($P = I^2R$)

Electrical energy transferred at higher voltage to reduce the current flow, hence reduce power loss during transmission.

($P = I^2R$)

- 33 C** Sinar katod mempunyai cas negatif, bergerak dalam halaju tinggi, boleh dipesongkan oleh medan elektrik dan medan magnet serta mempunyai momentum dan tenaga kinetik yang ditukarkan kepada tenaga cahaya semasa menghentam skrin pendafalour.
Cathode rays is a negatively charge, travels at high velocity, deflected by electric and magnetic field, has momentum and kinetic energy which converts to light energy when it reaches the fluorescent screen.
- 34 B** Elektron dan lohong menyeberangi lapisan susutan. Ini menyebabkan lapisan susutan berkurang, maka rintangan berkurang.
Electrons and holes drift to the opposite site. This will narrow the depletion layer thus reduce the resistance.
- 35 B** Kapasitor berfungsi untuk menyimpan cas dan menjadi perata arus dalam litar rektifikasi.
Capacitor function to store charge and become a current smoother in a rectification circuit.
- 36 C** Transistor digunakan sebagai suis untuk menghidupkan mentol secara automatik apabila keadaan sekeliling menjadi gelap.
Transistor is used as a switch to light up the bulb automatically when the surrounding become dark.
- 37 B** Cacat jisim / *Mass defect, m:*

$$m = [2.01410 + 3.01605] - [4.00260 + 1.00867]$$

$$= 0.01888$$

$$= 0.01888 \times 1.66 \times 10^{-27}$$

$$= 3.13408 \times 10^{-29} \text{ kg}$$
- Tenaga dibebaskan / *Energy released, E:*

$$E = mc^2$$

$$= (3.13408 \times 10^{-29})(3 \times 10^8)^2$$

$$= 2.820672 \times 10^{-12} \text{ J}$$
- 38 A** Rod kawalan dalam reaktor nuklear diperbuat daripada boron atau kadmium berfungsi untuk mengawal kadar tindak balas di dalam reaktor.
Control rods in a nuclear reactor made of boron or cadmium is used to control the rate of chain reaction inside the reactor.
- 39 C** Jasad hitam ialah suatu jasad unggul yang berupaya menyerap semua sinaran elektromagnet yang jatuh padanya.
A black body is an ideal body capable of absorbing all the electromagnetic radiation that falls on it.
- 40 C** Nilai pada pintasan pada paksi voltan menunjukkan voltan pengaktifan. (voltan terkecil yang melalui LED, di mana LED mengeluarkan cahaya)
The value on the intercept of the voltage axis shows activation voltage. (the smallest possible voltage across the LED just emits light)

Bahagian A/Section A

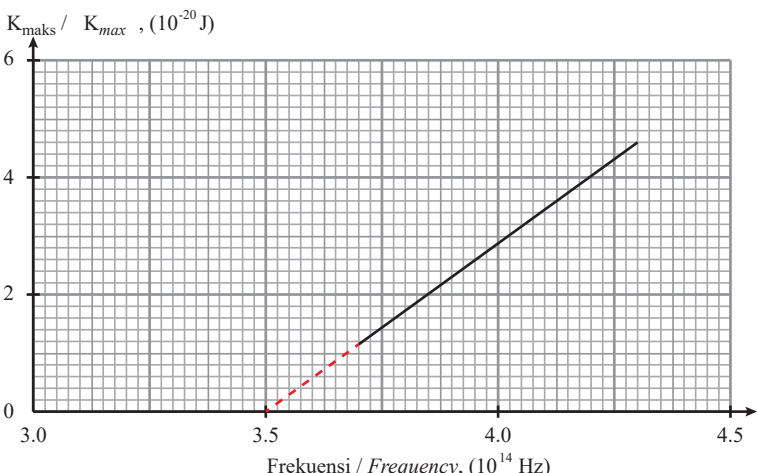
Soalan Questions		Jawapan Answers	Sub markah Subs marks	Markah total Total marks
1	(a)	✓ – Gelombang melintang <i>Transverse wave</i>	1	4
	(b)	Air merambat dari kawasan dalam ke kawasan cetek // Laju gelombang air berkurang // Arah perambatan dibiaskan mendekati garis normal <i>Water propagates from deep water region to shallow water region // The speed of water waves decreases // Direction of propagation refracted towards the normal</i>	1	
	(c)	Laju // Panjang gelombang. <i>Speed // Wavelength.</i>	1	
	(d)	Pembiasan gelombang / Pembiasan. <i>Refraction of wave / Refraction.</i>	1	
2	(a)	$\frac{F_1}{A_1} = \frac{F_2}{A_2}$ $\frac{25}{0.004} = \frac{F_2}{0.2}$ $F_2 = 1\,250\text{ N}$	1 1	5
	(b)	$\frac{A_2}{A_1} = \frac{1\,250}{25}$ $= 50 \text{ kali ganda / } 50 \text{ times}$	1 1	
	(c)	Takat didih tinggi // Kadar penyejatan rendah // Ketumpatan rendah. <i>High boiling point // Low evaporation rate // Low density.</i>	1	
3	(a)	Frekuensi minimum foton cahaya yang boleh menghasilkan kesan fotoelektrik pada satu jenis logam. <i>The minimum frequency of light photon required to produce photoelectric effect on a metal.</i>	1	1
	(b)	 <p>Frekuensi ambang / Threshold frequency, $f_0 = 3.5 \times 10^{14}\text{ Hz}$</p>	1 1	

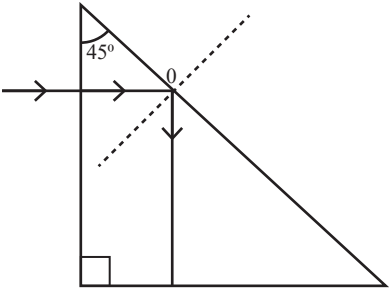
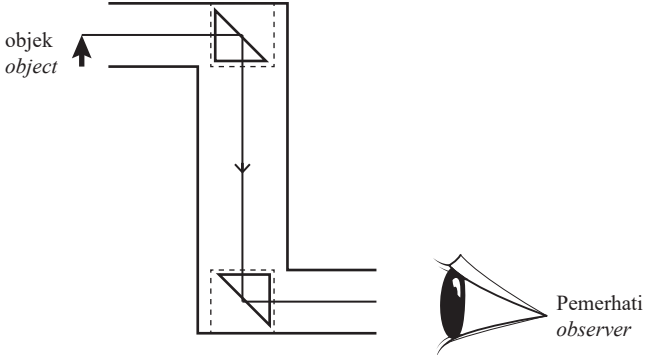
Soalan Questions	Jawapan Answers	Sub markah Subs marks	Markah total Total marks
(c)	Fungsi kerja/ <i>Work function</i> , $W = hf_o$ $= (6.63 \times 10^{-34}) (3.5 \times 10^{14})$ $= 2.3205 \times 10^{-19} \text{ J}$	1 1	6
(d)	Bertambah. <i>Increase.</i>	1	
4 (a)	Sudut tuju dalam medium yang berketumpatan optik tinggi apabila sudut biasan dalam medium yang berketumpatan optik rendah sama dengan 90° . <i>The angle of incidence in the medium of high optical density when the angle of refraction in the medium of lower optical density is equals to 90°.</i>	1	9
(b)	$n = \frac{1}{\sin c}$ $1.5 = \frac{1}{\sin c}$ $c = 41.8103^\circ$	1 1	
(c) (i)	 <p>Lintasan betul / <i>Correct path</i> Anak panah sinar cahaya / <i>Arrow of light rays</i></p>	1 + 1	
(ii)	Pantulan dalam penuh. <i>Total internal reflection.</i>	1	
(d)	 <p>Kedudukan dua prisma yang betul. <i>Position of prisms is correct.</i></p> <p>Pantulan dalam penuh berlaku dua kali. <i>Total internal reflection occur twice.</i></p>	1 2	

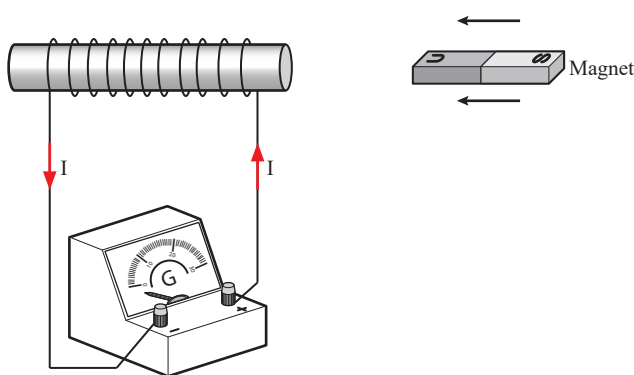
Soalan Questions		Jawapan Answers	Sub markah Subs marks	Markah total Total marks	
5	(a)	Penghasilan d.g.e. aruhan merentasi suatu konduktor apabila terdapat gerakan relatif antara konduktor itu dengan suatu medan magnet atau apabila konduktor itu berada di dalam medan magnet yang berubah. <i>Production of an induced e.m.f. in a conductor when there is relative motion between the conductor and a magnetic field or when the conductor is in a changing magnetic field.</i>	1	9	
	(b)	Arus aruhan. <i>Induced current.</i>	1		
	(c)	(i)	Bilangan lilitan solenoid Rajah 5.1(a) > 5.2(b). <i>The number of turns of the solenoid Diagram 5.1(a) > 5.2(b).</i>		1
		(ii)	Kekuatan medan magnet Rajah 5.1(a) > 5.2(b). <i>The strength of magnetic field Diagram 5.1(a) > 5.2(b).</i>		1
		(iii)	Magnitud arus aruhan Rajah 5.1(a) > 5.2(b). <i>The magnitude of induced current Diagram 5.1(a) > 5.2(b).</i>		1
	(d)	(i)	Semakin bertambah bilangan lilitan solenoid, semakin bertambah kekuatan medan magnet. <i>The more the number of turns of the solenoid, the stronger the magnetic field.</i>		1
		(ii)	Semakin bertambah kekuatan medan magnet, semakin bertambah magnitud arus aruhan. <i>The increase of magnetic field, the increase of magnitude of induced current.</i>		1
	(e)	Hukum Faraday. <i>Faraday's Law.</i>	1		
	(f)		1		
	6	(a)	Daya per unit luas. <i>Force per unit area.</i>		1
(b)		✓ tekanan gas. <i>pressure of gas.</i>	1		
(c)		(i)	Isi padu udara dalam Rajah 6.1(b) < Isi padu udara dalam Rajah 6.1(a). <i>Air volume in Diagram 6.1(b) < Air volume in Diagram 6.1(a).</i>	1	
		(ii)	Tekanan udara dalam Rajah 6.1(b) > Tekanan udara dalam Rajah 6.1(a). <i>Air pressure in Diagram 6.1(b) > Air pressure in 6.1(a).</i>	1	
		(iii)	Bilangan zarah-zarah udara tidak berubah // Sama. <i>Number of air particles do not change // Same.</i>	1	
(d)		(i) Semakin bertambah isi padu udara dalam pam basikal, semakin berkurang tekanan udara yang dihasilkan. <i>The volume of air in bicycle pump increases, the pressure produced decreases.</i>	1		

Soalan Questions		Jawapan Answers	Sub markah Subs marks	Markah total Total marks
	(ii)	Hukum Boyle. <i>Boyle's law.</i>	1	9
	(e)	$P_1 V_1 = P_2 V_2$ $(5)(200) = (25)(V_2)$ $V_2 = 40 \text{ cm}^3$	1 1	
7	(a)	Pemanjangan suatu spring adalah berkadar terus dengan daya yang bertindak ke atas spring jika tidak melebihi had kenyal spring itu. <i>The extension of a spring is directly proportional to the force applied on the spring provided the elastic limit of the spring is not exceeded.</i>	1	9
	(b)	<p>Daya / N Force</p> <p>Pemanjangan / cm Extension</p>	1	
	(c)	(i) – Tinggi / <i>High</i> . – Mampu menahan daya tinggi / <i>Withstand high force</i> .	1 1	
		(ii) – Kecil // Rendah / <i>Small // Low</i> . – Ringan // Jisim kecil. / <i>Light // Small mass</i> .	1 1	
		(iii) – Tinggi / <i>High</i> . – Boleh kembali ke bentuk asal setelah daya tinggi yang dikenakan ke atas spring dialihkan. <i>Able to return to initial shape and size after the force acting is removed.</i>	1 1	
	(iv)	R	1	
8	(a)	Pengering rambut menggunakan/melepaskan 1 100 J tenaga elektrik dalam satu saat apabila dibekalkan voltan sebanyak 240 V. <i>The hairdryer use/dissipated 1 100 J of electrical energy in one second when a voltage of 240 V is supplied.</i>	1	9
	(b)	$R = \frac{\rho l}{A}$ $= \frac{(1.1 \times 10^{-6})(2)}{5 \times 10^{-9}}$ $= 440 \Omega$	1 1	

Soalan Questions		Jawapan Answers	Sub markah Subs marks	Markah total Total marks	
(c)	(i)	Bahan elemen pemanas – Nikrom // Rintangan tinggi <i>Type of heating element – Nichrome // High resistance</i> Sebab – Rintangan tinggi // Banyak haba dihasilkan <i>Reason – High resistance // Produced more heat energy</i>	1 1	9	
	(ii)	Ketebalan dawai elemen pemanas – Kecil // Nipis <i>Thickness of the heating element – Small // Thin</i> Sebab – Rintangan tinggi // Banyak haba dihasilkan <i>Reason – High resistance // Produced more heat energy</i>	1 1		
	(iii)	Kuasa kipas yang digunakan – Tinggi // Besar <i>Power of the fan – High // Great // Big</i> Sebab – Banyak udara panas ditiup <i>Reason – Blow more hot air</i>	1 1		
9	(a)	(i)	Tenaga keupayaan graviti bermaksud tenaga yang diperolehi oleh suatu objek disebabkan kedudukannya dari pusat Bumi. <i>Gravitational potential energy is the energy gained by an object due to its position from the centre of the Earth.</i>	1	
		(ii)	$u = -\frac{GMm}{r}$ $u = -\frac{(6.67 \times 10^{-11})(5.97 \times 10^{24})(300)}{(6.37 \times 10^6) + (3 \times 10^5)}$ $= -1.79 \times 10^{10} \text{ J (dengan unit / with unit)}$	1 1	
		(iii)	$T = \sqrt{\frac{4\pi^2 r^3}{GM}}$ $(86\,400)^2 = \frac{4\pi^2 r^3}{(6.67 \times 10^{-11})(5.97 \times 10^{24})}$ $r = 4.22 \times 10^7 \text{ m (dengan unit / with unit)}$	1 + 1 1	
	(b)	– Arah gerakan satelit sama dengan arah putaran Bumi. <i>Direction of satellite motion same as the direction of Earth rotation.</i> – Tempoh putaran orbit adalah 24 jam. <i>Orbital period is 24 hours.</i> – Berada di atas kedudukan geografi yang sama di permukaan Bumi. <i>Located at the same geographical location on Earth surface.</i> – Sesuai digunakan sebagai satelit komunikasi. <i>Suitable to be use as communication satellite.</i>	1 1 1 1		

Soalan Questions		Jawapan Answers		Sub markah Subs marks	Markah total Total marks
(c)		Cadangan/Suggestion	Sebab/Reason		
		Jenis satelit geopegun. <i>Type of satellite geostationary.</i>	Kedudukan geografi satelit di permukaan Bumi pada lokasi tetap. <i>Geographical position of satellite above Earth at fixed location.</i>	1 + 1	
		Tempoh orbit 24 jam. <i>Orbital period 24 hours.</i>	Sama dengan tempoh putaran lengkap Bumi. <i>Same with the complete period of rotation of Earth.</i>	1 + 1	
		Arah edaran dari Barat ke Timur. <i>Direction of orbit from West to East.</i>	Arah putaran sama dengan arah putaran Bumi. <i>The direction of rotation is the same as the direction of rotation of the Earth.</i>	1 + 1	
		Bilangan satelit 3. <i>Number of satellites 3.</i>	Memastikan gelombang penyiaran sampai ke seluruh dunia. <i>Ensure the broadcast reaches the whole world.</i>	1 + 1	
		Satelit X. <i>Satellite X.</i>	Kedudukan geografi satelit di permukaan Bumi pada lokasi tetap, tempoh orbit 24 jam, arah edaran Barat ke Timur, bilangan satelit 3. <i>Geographical position of satellite above Earth at fixed location, orbital period 24 hours, direction of orbit from West to East, number of satellites 3.</i>	1 + 1	
					20
10	(a)	Pelakuran nuklear. <i>Nuclear fusion.</i>		1	
	(b)	– Satu nukleus yang lebih besar, helium, terbentuk dan satu neutron dibebaskan. <i>One larger nucleus, helium is formed, and a neutron is released.</i>		1	
		– Susutan jisim diubah menjadi tenaga yang dibebaskan. <i>Some mass (mass defect) is converted into energy and released.</i>		1	
		${}^2_1\text{H} + {}^3_1\text{H} \rightarrow {}^4_2\text{He} + {}^1_0\text{n} + \text{tenaga/energy}$		2	
(c)	Susutan jisim / <i>Mass defect</i> , $m = [2.014102 + 3.016050] - [4.002603 + 1.008665]$ $= 0.018884 \text{ u.j.a / a.m.u}$ $= 0.018884 \times 1.66 \times 10^{-27} \text{ kg}$ $= 3.134744 \times 10^{-29} \text{ kg}$ $E = mc^2$ $= (3.134744 \times 10^{-29})(3 \times 10^8)^2$ $= 2.8212696 \times 10^{-12} \text{ J}$		1 1 1 1 1		

Soalan Questions		Jawapan Answers	Sub markah Subs marks	Markah total Total marks												
(d)		<table border="1"> <thead> <tr> <th>Ciri-ciri/Characteristics</th> <th>Sebab/Reason</th> </tr> </thead> <tbody> <tr> <td>Bahan api reaktor nuklear: Uranium-235 <i>The fuel of the nuclear reactor: Uranium-235</i></td> <td>Nukleus yang lebih tidak stabil. <i>More unstable nucleus.</i></td> </tr> <tr> <td>Separuh hayat bahan api: Panjang <i>Half-life of fuel: Long</i></td> <td>Ia dapat digunakan untuk jangka masa panjang. <i>It can be used for a long time.</i></td> </tr> <tr> <td>Tindak balas kimia bagi penghasilan gas pernafasan: Elektrolisis air <i>A chemical reaction to produce gas for breathing: Water electrolysis</i></td> <td>Gas oksigen untuk pernafasan dapat dihasilkan. <i>Oxygen gas for respiration can be produced.</i></td> </tr> <tr> <td>Perisai reaktor nuklear: Konkrit <i>Shield of nuclear reactor: Concrete</i></td> <td>Menghalang kebocoran sinaran radioaktif dari teras ke reaktor. <i>Prevents leakage of radioactive radiation from the reactor core.</i></td> </tr> <tr> <td>Pilih J. <i>Choose J.</i></td> <td>Bahan api adalah uranium-235, Separuh hayat yang panjang, tindak balas kimia elektrolisis air dan perisai konkrit. <i>Because of the uranium-235 fuel, long half-life, water electrolysis chemical reaction and concrete shield.</i></td> </tr> </tbody> </table>	Ciri-ciri/Characteristics	Sebab/Reason	Bahan api reaktor nuklear: Uranium-235 <i>The fuel of the nuclear reactor: Uranium-235</i>	Nukleus yang lebih tidak stabil. <i>More unstable nucleus.</i>	Separuh hayat bahan api: Panjang <i>Half-life of fuel: Long</i>	Ia dapat digunakan untuk jangka masa panjang. <i>It can be used for a long time.</i>	Tindak balas kimia bagi penghasilan gas pernafasan: Elektrolisis air <i>A chemical reaction to produce gas for breathing: Water electrolysis</i>	Gas oksigen untuk pernafasan dapat dihasilkan. <i>Oxygen gas for respiration can be produced.</i>	Perisai reaktor nuklear: Konkrit <i>Shield of nuclear reactor: Concrete</i>	Menghalang kebocoran sinaran radioaktif dari teras ke reaktor. <i>Prevents leakage of radioactive radiation from the reactor core.</i>	Pilih J. <i>Choose J.</i>	Bahan api adalah uranium-235, Separuh hayat yang panjang, tindak balas kimia elektrolisis air dan perisai konkrit. <i>Because of the uranium-235 fuel, long half-life, water electrolysis chemical reaction and concrete shield.</i>	1 + 1	20
	Ciri-ciri/Characteristics	Sebab/Reason														
	Bahan api reaktor nuklear: Uranium-235 <i>The fuel of the nuclear reactor: Uranium-235</i>	Nukleus yang lebih tidak stabil. <i>More unstable nucleus.</i>														
	Separuh hayat bahan api: Panjang <i>Half-life of fuel: Long</i>	Ia dapat digunakan untuk jangka masa panjang. <i>It can be used for a long time.</i>														
	Tindak balas kimia bagi penghasilan gas pernafasan: Elektrolisis air <i>A chemical reaction to produce gas for breathing: Water electrolysis</i>	Gas oksigen untuk pernafasan dapat dihasilkan. <i>Oxygen gas for respiration can be produced.</i>														
	Perisai reaktor nuklear: Konkrit <i>Shield of nuclear reactor: Concrete</i>	Menghalang kebocoran sinaran radioaktif dari teras ke reaktor. <i>Prevents leakage of radioactive radiation from the reactor core.</i>														
Pilih J. <i>Choose J.</i>	Bahan api adalah uranium-235, Separuh hayat yang panjang, tindak balas kimia elektrolisis air dan perisai konkrit. <i>Because of the uranium-235 fuel, long half-life, water electrolysis chemical reaction and concrete shield.</i>															
		1 + 1														
		1 + 1														
		1 + 1														
		1 + 1														
		1 + 1														
11	(a)	npn	1													
	(b)	– Pada hari panas, rintangan termistor rendah, maka voltan termistor rendah. <i>In a hot day, resistance of thermistor is low, voltage of thermistor is low.</i>	1													
		– Voltan tapak tinggi, maka arus tapak yang kecil mengalir. <i>Base voltage is high, low base current flow.</i>	1													
		– Transistor dihidupkan. <i>Transistor is switched on.</i>	1													
		– Arus pengumpul yang besar mengalir, maka kipas dihidupkan. <i>Collector current flows, fan is switched on.</i>	1													
(c)	– Apabila rintangan termistor rendah, voltan merentasi termistor juga berkurang. <i>When the resistance of the thermistor is low, the voltage across it decreases.</i>	1														
	– Apabila rintangan termistor tinggi, voltan merentasi termistor akan meningkat. <i>When the resistance of the thermistor is high, the voltage across it increases.</i>	1														
	– Berdasarkan konsep litar pembahagi voltan, apabila voltan merentasi termistor berkurang, voltan merentasi perintang R akan meningkat. <i>Based on the potential divider concept when the voltage across the thermistor decreases, the voltage across the resistor R increases</i>	1														

Soalan Questions		Jawapan Answers	Sub markah Subs marks	Markah total Total marks												
		<p>– Apabila voltan merentasi perintang R melebihi voltan minimum merentasi tapak, arus tapak, I akan mengalir dan transistor dapat dihidupkan. <i>When the voltage across the resistor R exceeds the minimum voltage across the base, the base current, I will flow, and the transistor will be turn on.</i></p> <p>– Maka, nilai rintangan termistor yang rendah dan nilai rintangan perintang R yang tinggi adalah syarat untuk menghidupkan kipas. <i>Thus, a low thermistor resistance value and a high resistor R resistance value is a condition to turn on the fan.</i></p>	1 1													
	(d)	<table border="1"> <thead> <tr> <th>Modifikasi/Modification</th> <th>Penerangan/Explanation</th> </tr> </thead> <tbody> <tr> <td>Komponen P diganti dengan termistor. <i>Component P is replaced with thermistor.</i></td> <td>Untuk mengesan haba apabila suhu tinggi. <i>To detect heat when temperature is high.</i></td> </tr> <tr> <td>Tambah perintang tapak. <i>Add a base resistor.</i></td> <td>Untuk menghadkan arus tapak. <i>To limit the base current.</i></td> </tr> <tr> <td>Mentol diganti dengan suis geganti. <i>Bulb replaced with relay switch.</i></td> <td>Untuk menghidupkan litar sekunder. <i>To switch on the secondary circuit.</i></td> </tr> <tr> <td>Tambah motor dalam litar sekunder. <i>Add motor in secondary circuit.</i></td> <td>Untuk menghidupkan penyiram air. <i>To switch on the water sprinkler.</i></td> </tr> <tr> <td>Guna 240 V dalam litar sekunder. <i>Use 240 V in secondary circuit.</i></td> <td>Untuk menghidupkan motor. <i>To switch on the motor.</i></td> </tr> </tbody> </table>	Modifikasi/Modification	Penerangan/Explanation	Komponen P diganti dengan termistor. <i>Component P is replaced with thermistor.</i>	Untuk mengesan haba apabila suhu tinggi. <i>To detect heat when temperature is high.</i>	Tambah perintang tapak. <i>Add a base resistor.</i>	Untuk menghadkan arus tapak. <i>To limit the base current.</i>	Mentol diganti dengan suis geganti. <i>Bulb replaced with relay switch.</i>	Untuk menghidupkan litar sekunder. <i>To switch on the secondary circuit.</i>	Tambah motor dalam litar sekunder. <i>Add motor in secondary circuit.</i>	Untuk menghidupkan penyiram air. <i>To switch on the water sprinkler.</i>	Guna 240 V dalam litar sekunder. <i>Use 240 V in secondary circuit.</i>	Untuk menghidupkan motor. <i>To switch on the motor.</i>	1 + 1 1 + 1 1 + 1 1 + 1 1 + 1	
Modifikasi/Modification	Penerangan/Explanation															
Komponen P diganti dengan termistor. <i>Component P is replaced with thermistor.</i>	Untuk mengesan haba apabila suhu tinggi. <i>To detect heat when temperature is high.</i>															
Tambah perintang tapak. <i>Add a base resistor.</i>	Untuk menghadkan arus tapak. <i>To limit the base current.</i>															
Mentol diganti dengan suis geganti. <i>Bulb replaced with relay switch.</i>	Untuk menghidupkan litar sekunder. <i>To switch on the secondary circuit.</i>															
Tambah motor dalam litar sekunder. <i>Add motor in secondary circuit.</i>	Untuk menghidupkan penyiram air. <i>To switch on the water sprinkler.</i>															
Guna 240 V dalam litar sekunder. <i>Use 240 V in secondary circuit.</i>	Untuk menghidupkan motor. <i>To switch on the motor.</i>															
				20												

KERTAS MODEL SIJIL PELAJARAN MALAYSIA 2023 SET 2

Kertas 1 / Paper 1

- 1 **D** Daya ialah kuantiti vektor. Daya mempunyai arah dan magnitud yang tersendiri. Tenaga dan kuasa mempunyai magnitud tetapi tidak mempunyai hala tuju. Tekanan mempunyai magnitud tetapi tidak mempunyai arah tertentu. Tekanan atmosfera bertindak dalam semua arah.
Force is a vector quantity. Force has its own direction and magnitude. Energy and power have magnitude but do not have direction. Pressure has magnitude but does not have a particular direction. Atmospheric pressure acts in all directions.
- 2 **C** Pemboleh ubah bergerak balas merujuk kepada paksi-y Berkadar terus kerana garis lurus melalui origin
Responding variable refer to y-axis of graph Directly proportional because the straight-line pass-through origin
- 3 **C** Jarak = Luas trapezium + Luas segitiga
Distance = Area of trapezium + Area of triangle

$$= \left[\frac{1}{2} \times (20 + 12) \times 8 \right] + \left[\frac{1}{2} \times 4 \times 8 \right]$$

$$= 144 \text{ m}$$
- 4 **A** Inersia ialah kecenderungan sesuatu objek untuk kekal pada keadaan asalnya.
Inertia is the tendency of an object to remain at its original situation.

- 5 B Kedua-dua objek bergabung dan bergerak bersama-sama dengan halaju sepunya selepas perlanggaran mengalami perlanggaran tak kenyal. Momentum kereta diabadikan, tenaga kinetik tidak diabadikan dan jumlah tenaga diabadikan.

The two objects combine and move together with a common velocity after the collision experience inelastic collision. Their momentum is conserved, kinetic energy is not conserved and total energy is conserved.

- 6 A Menurut Hukum Kepler Kedua: Planet bergerak lebih cepat apabila ia lebih dekat dengan Matahari dan bergerak lebih perlahan apabila ia jauh dari Matahari.

According to Kepler Second Law: Planet moves faster when it is closer to the Sun and moves slower when it is further from the Sun.

$$7 \quad C \quad F = \frac{Gm_1m_2}{r^2} \rightarrow F \propto \frac{1}{r^2}$$

Daya graviti, F berkadar songsang dengan jarak satelit, r

Nilai r lebih rendah, nilai F lebih tinggi

Force of gravity, F is inversely proportional to distance of satellite, r

A lower value of r, the higher value of F

$$g = \frac{GM}{r^2} \rightarrow g \propto \frac{1}{r^2}$$

Pecutan graviti, g berkadar songsang dengan jarak satelit, r

Nilai r yang lebih rendah, nilai g lebih tinggi

Gravitational acceleration, g is inversely proportional to distance of satellite, r

A lower value of r, the higher value of g

- 8 B Anggarkan M = jisim Bumi, R = jejari Bumi, v_x = halaju lepas planet X
Diberi jisim planet X = 400M, jejari planet X = 10R

Assume M = mass of Earth, R = radius of Earth, v_x = escape velocity of planet X

Given mass of planet X = 400M, radius of planet X = 10R

$$v = \sqrt{\frac{2GM}{R}}$$

(1) ÷ (2) :

$$11.2 = \sqrt{\frac{2GM}{R}} \dots\dots\dots(1)$$

$$\frac{v_x}{11.2} = \frac{\sqrt{\frac{80GM}{R}}}{\sqrt{\frac{2GM}{R}}}$$

$$v_x = \sqrt{\frac{2G(400M)}{10R}}$$

$$= \sqrt{\frac{80GM}{R}} \dots\dots\dots(2)$$

$$\frac{v_x}{11.2} = \sqrt{\frac{80GM}{R} \times \frac{R}{2GM}}$$

$$V_x = 11.2 \times \sqrt{40} \\ = 70.84 \text{ ms}^{-1}$$

- 9 A Konduktor haba yang baik akan memberi peningkatan suhu yang paling tinggi pada masa, jisim dan bekalan kuasa yang sama.

A good heat conductor will give the highest temperature rise for the same time, mass and power supply.

$$Pt = mc\theta$$

$$\theta = \frac{Pt}{mc}$$

$$\theta \propto \frac{1}{c}$$

Peningkatan suhu, berkadar songsang dengan c. Nilai c yang kecil akan menghasilkan peningkatan suhu yang lebih tinggi iaitu sifat konduktor haba yang terbaik.

The increase in temperature, θ is inversely proportional to c. A small value of c will result in a higher temperature increase which is the characteristic of the best heat conductor.

- 10 B Pada suhu mutlak 0 K (= -273 °C), molekul gas tidak bergerak dan tenaga kinetiknya adalah sifar.

At the absolute temperature of 0 K (= -273 °C), gas molecules are not moving and their kinetic energy is zero.

11 B
$$\theta = \frac{l_{\theta} - l_0}{l_{100} - l_0} \times 100$$

$$40 = \frac{l_{\theta} - 1.0}{28.0 - 1.0} \times 100$$

$$l_{\theta} = 11.8 \text{ cm}$$

12 C Daya paduan untuk OX dan OY ialah pepenjuru segi empat selari dari titik O
Resultant force of OX and OY is the diagonal of parallelogram from point O

13 D Anggapkan pemanjangan satu spring = x, bilangan spring = n

Assume the extension of one spring = x, number of spring = n

Jumlah pemanjangan spring yang disusun secara siri = nx

Total extension of spring arranged in series = nx

Jumlah pemanjangan spring secara selari = $\frac{n}{x}$

Total extension of spring arranged in parallel = $\frac{n}{x}$

Jumlah pemanjangan susunan spring X = $\frac{x}{4} + \frac{x}{2} = \frac{3}{4}x$

Total extension of the spring arrangement X = $\frac{x}{4} + \frac{x}{2} = \frac{3}{4}x$

Jumlah pemanjangan susunan spring Y = $\frac{x}{3}$

Total extension of the spring arrangement Y = $\frac{x}{3}$

Jumlah pemanjangan susunan spring Z = $\frac{x}{2} + x = \frac{3}{2}x$

Total extension of the spring arrangement Z = $\frac{x}{2} + x = \frac{3}{2}x$

$Z > X > Y$

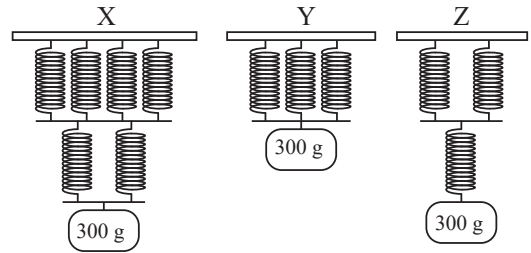

14 C Pecutan graviti sama di semua lokasi atas Bumi

Acceleration gravity are same at every location on Earth

Tenaga kinetik = $\frac{1}{2}mv^2$, Tenaga keupayaan graviti = mgh

m tidak sama, tenaga kinetik, tenaga keupayaan graviti, halaju tidak sama

Kinetic energy = $\frac{1}{2}mv^2$, Gravitational potential energy = mgh

m different, kinetic energy, gravitational potential energy, velocity different

15 A $F = ma$

$$(2000)(9.81) \sin 12^\circ - 500 = (2000)(a)$$

$$a = 1.79 \text{ ms}^{-2}$$

16 B Pembelauan gelombang ialah fenomena di mana gelombang tersebar semasa ia melalui celah atau di sekeliling halangan kecil.

Diffraction of waves is a phenomenon in which waves spread out as they pass through a gap or round a small obstacle.

Pulau di Rajah 13 merupakan halangan kecil.

Island in Diagram 13 represent a small obstacle.

17 C Kesan pembiasan dari kawasan air dalam ke kawasan air cetek: Kelajuan gelombang berkurang dan panjang gelombang berkurang.

Effects of refraction from deep water region to shallow water region: Wave speed decreases and wavelength of wave decreases.

18 B Dalam spektrum elektromagnet, gelombang disusun daripada tenaga rendah kepada tenaga tinggi (atau sebaliknya). Penghujung tenaga tinggi yang bermula dengan sinar gama diikuti oleh sinar-X, sinar ultraungu, sinar inframerah, gelombang mikro dan berakhir dengan gelombang radio.

In the electromagnetic spectrum, waves are arranged from low energy to high energy (or vice versa). The high energy end which starts with gamma rays is followed by X-ray, ultraviolet ray, infrared ray, microwave and ends with radio wave.

- 19 D Diberi /Given, $f = 15 \text{ cm}$, $u = 20 \text{ cm}$

$$\frac{1}{f} = \frac{1}{u} + \frac{1}{v}$$

$$\frac{1}{15} = \frac{1}{20} + \frac{1}{v}$$

$$v = 60 \text{ cm}$$

- 20 B A Kanta objektif dan kanta mata adalah kanta cembung

A *The objective lens and eyepiece lens are convex lens*

C / D *Pelarasan normal = jarak fokus kanta mata + jarak fokus kanta objektif*

C / D *Normal adjustment = focal length of eyepiece + focal length of objective lens*

- 21 A Rajah 17 menunjukkan seorang lelaki berdiri dekat dengan cermin cekung di mana jarak objek kurang daripada panjang fokus cermin cekung (ciri-ciri imej yang terbentuk: maya, tegak dan membesar).

Diagram 17 shows a man stands near to a concave mirror with the object distance less than its focal length (image characteristic formed: virtual, upright and magnified)

- 22 A Tekanan atmosfera bertindak pada permukaan laut dan adalah malar di setiap titik atas permukaan laut.

Tekanan air = ρhg (tekanan air berkadar kedalaman air), kedalaman ketam > ikan

Atmospheric pressure acts on the sea surface and is constant at every point above the sea surface.

Water pressure = ρhg (water pressure directly proportional to water depth), depth of crab > fish

- 23 B Prinsip Bernoulli menyatakan bahawa tekanan bendalir yang bergerak berkurangan apabila halaju bendalir bertambah dan begitu juga sebaliknya.

Kelajuan aliran udara pada $X > Y$, tekanan pada $X < Y$.

Bernoulli's principle states that the pressure of a moving fluid decreases as the velocity of the fluid increases and vice versa.

Speed of air flow at $X > Y$, pressure at $X < Y$.

- 24 B Daya apungan / Buoyant force,

$$F_B = \rho Vg$$

$$= (1.184 \times 500 \times 9.81) = 5\,807.52 \text{ N}$$

Berat / Weight,

$$W = mg$$

$$= 250 \times 9.81 = 2\,452.5 \text{ N}$$

Daya paduan / Resultant force

$$= 5\,807.52 - 2\,452.5$$

$$= 3\,355.02 \text{ N}$$

- 25 C Frekuensi ayunan bola polistirena bertambah menunjukkan kekuatan medan elektrik bertambah.

$$E = \frac{V}{d}$$

E = kekuatan medan elektrik, V = beza keupayaan antara dua plat yang selari, d = jarak antara dua plat selari. E berkadar terus dengan V dan berkadar songsang dengan d. E meningkat apabila V meningkat atau d berkurang

The frequency of oscillation of the polystyrene ball increases indicating the strength of the electric field increases.

$$E = \frac{V}{d}$$

E = electric field strength, V = potential difference between two parallel plates, d = distance between two parallel plates.

E is directly proportional to V and inversely proportional to d. E increases as V increases or d decreases.

- 26 A Anggap R = perintang mentol

Assume R = resistance of bulb

$$V = IR$$

$$9 = (1.5)(5 + R)$$

$$R = 1 \, \Omega$$

Jumlah rintangan untuk perintang $5\ \Omega$ and $10\ \Omega$, R_p

Total resistance of resistor $5\ \Omega$ and $10\ \Omega$, R_p

$$\frac{1}{R_p} = \frac{1}{5} + \frac{1}{10}$$

$$R_p = 3.33\ \Omega$$

$$R_T = R_p + R$$

$$= 4.33\ \Omega$$

$$V = IR$$

$$9 = I(4.33)$$

$$I = 2.08\ \text{A}$$

- 27 B** Gelombang bunyi adalah gelombang mekanikal kerana ia memerlukan medium untuk memindahkan tenaga dari satu titik ke titik yang lain. Gelombang bunyi ialah gelombang membujur kerana zarah medium bergetar pada arah yang selari dengan arah perambatan gelombang.

Sound wave is mechanical wave because it required medium to transfer energy from one point to another. Sound wave is longitudinal wave because particles of the medium vibrate in the direction to the direction of propagation of the wave.

- 28 C** $E = V + Ir$

$$V = -(r)I + E$$

$$y = mx + c$$

E (D.g.e/ $E.m.f$) = pintasan- V / V -intercept

r = kecerunan graf/ *Gradient of graph*

- 29 D**

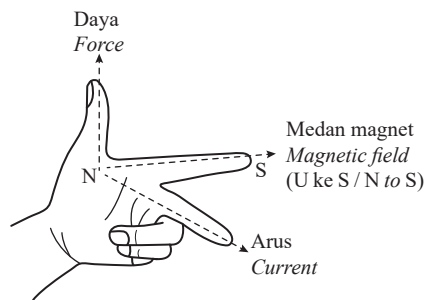

Guna petua tangan kiri Fleming untuk menentukan arah daya

Use Fleming's left-hand rule to determine the direction of force

- 30 D** Ammeter mengukur arus dalam gegelung primer, I_p .

Ammeter measure current in the primer coil, I_p .

Dalam sebuah transformer unggul,

In an ideal transformer,

$$P_{in} = P_{out}$$

$$(240)I_p = (5)(1.5)$$

$$V_s I_s = 7.5$$

$$(5)I_s = 7.5$$

$$I_s = 1.5\ \text{A}$$

$$I_p = \frac{7.5}{240}$$

$$= 0.031\ \text{A}$$

$$= 0.031 \times 1\ 000$$

$$= 31\ \text{mA}$$

- 31 D** D.g.e teraruh solenoid bertambah apabila kelajuan gerakan relatif bertambah, bilangan lilitan solenoid bertambah dan kekuatan medan magnet bertambah. Apabila magnet dilepaskan dari kedudukan yang lebih rendah, magnet bergerak lebih perlahan. Kadar pemotongan medan magnet dikurangkan. Arus dihasilkan berkurang.

The induced e.m.f. of a solenoid increases when the speed of relative motion increases, the number of turns of the solenoid increases and the strength of the magnetic field increases. When the magnet is released from a lower position, the magnet moves slower. The rate of cutting of the magnetic field is reduce. Less current is produced.

32 D Arus dapat mengalir melalui diod atas yang disambungkan pincang ke hadapan kepada bekalan kuasa tetapi arus dihentikan oleh diod bawah yang disambungkan dalam pincang songsang kepada bekalan kuasa.

Current able to flow through the upper diode which is connected forward bias to power supply but current is stopped by lower diode which is connected in reversed bias to power supply.

33 C $\frac{1}{2}mv^2 = eV$
 $\frac{1}{2}(9 \times 10^{-31})v^2 = (1.6 \times 10^{-19})(5000)$
 $v = 4.22 \times 10^7 \text{ ms}^{-1}$

34 A Dalam separuh kitaran positif, diod Q dan R dipincang ke hadapan manakala P dan S dipincang terbalik. Dalam separuh kitaran negatif, diod P dan S dipincang ke hadapan manakala Q dan R dipincang terbalik.
In positive half cycle, diode Q and R are forward biased while P and S are reversed biased
In negative half cycle, diode P and S are forward biased while Q and R are reversed biased

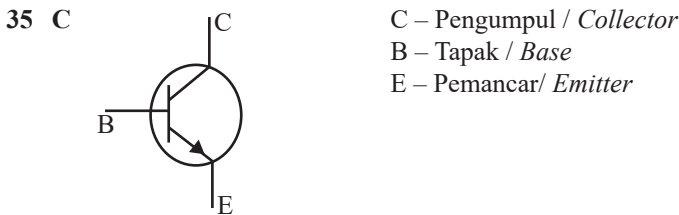

36 B $T_{\frac{1}{2}} = 6 \text{ jam / hours}$
 Separuh hayat / Number of half-life = $\frac{18}{6} = 3T_{\frac{1}{2}}$
 $65\ 000 \xrightarrow{T_{\frac{1}{2}}} 32\ 500 \xrightarrow{T_{\frac{1}{2}}} 16\ 250 \xrightarrow{T_{\frac{1}{2}}} 8\ 125$

37 A $E = mc^2$
 E – Jumlah tenaga yang dibebaskan
Total energy released
 m – Cacat jisim
Mass defect
 c – Laju cahaya
Speed of light

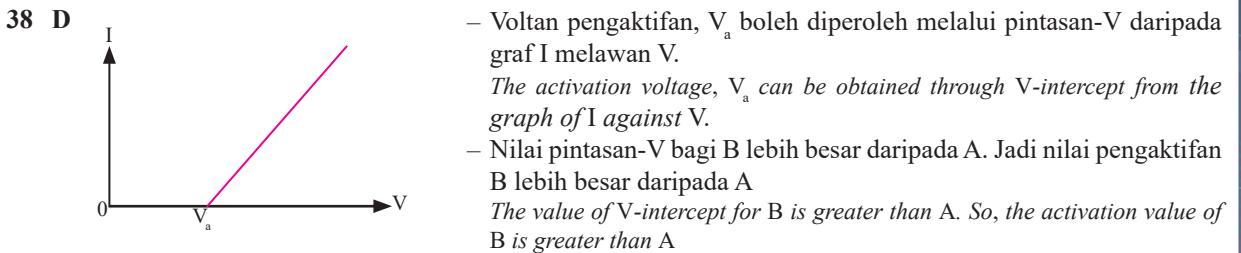

39 A Elektron tidak terpancar dari permukaan logam kecuali frekuensi gelombang cahaya tuju lebih besar daripada nilai frekuensi ambang logam itu.
Electrons are not emitted from the metal surface unless the frequency of the light wave is greater than the critical value of threshold frequency of the metal.

40 C $W = 3.7 \times 1.6 \times 10^{-19} \text{ J}$
 $= 5.92 \times 10^{-19} \text{ J}$
 $W = hf_0$
 $5.92 \times 10^{-19} = 6.63 \times 10^{-34} (f_0)$
 $f_0 = 8.93 \times 10^{14} \text{ Hz}$

Bahagian A/Section A

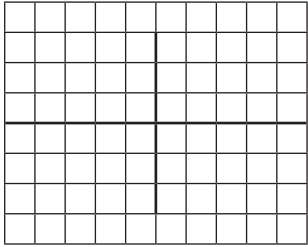
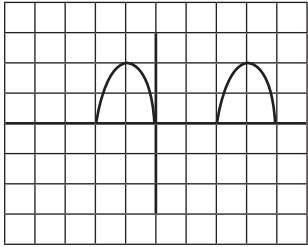
Soalan Questions		Jawapan Answers	Sub markah Subs marks	Markah total Total marks
1	(a)	✓ – kesan fotoelektrik <i>photoelectric effect</i>	1	4
	(b)	Frekuensi ambang <i>Threshold frequency</i>	1	
	(c)	– Keamatan bertambah <i>Intensity increases</i>	1	
– Bilangan elektron bertambah <i>Number of electrons increases</i>		1		
2	(a)	Pincang depan <i>Forward biased</i>	1	5
	(b)	– Lapisan susutan nipis <i>Depletion layer thin</i>	1	
		– Voltan simpang berkurang <i>Junction voltage decreases</i> – Rintangan diod berkurang <i>Resistance of diode decrease</i> (Mana-mana dua jawapan) (<i>Any two answers</i>)	1	
(c)	 <p>Rajah 2.2 (b) <i>Diagram 2.2 (b)</i></p>  <p>Rajah 2.3 (b) <i>Diagram 2.3 (b)</i></p>	1		
			1	
3	(a)	Kadar perubahan sesaran <i>Rate change of displacement</i>	1	
	(b)	Nyah pecutan // Halaju berkurang dengan seragam <i>Deceleration // Uniformly decreasing velocity</i>	1	

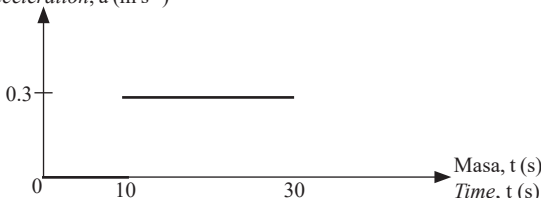
Soalan Questions	Jawapan Answers	Sub markah Subs marks	Markah total Total marks
(c)	Jumlah luas bawah graf <i>Total area under the graph:</i> $= (10 \times 10) + \left[\frac{1}{2} \times (10 + 16) \times 20 \right] + \left(\frac{1}{2} \times 20 \times 16 \right)$ $= 100 + 260 + 160$ $= 520 \text{ m}$	1 1	6
(d)	Pecutan, a (m s ⁻²) <i>Acceleration, a (m s⁻²)</i>  Garis mengufuk pada a = 0 ms ⁻² untuk t = (0 – 10 s) – 1 markah <i>Horizontal line at a = 0 ms⁻² for t = (0 – 10 s) – 1 mark</i> Garis mengufuk pada a = 0.3 ms ⁻² untuk t = (10 – 30 s) – 1 markah <i>Horizontal line at a = 0.3 ms⁻² for t = (10 – 30 s) – 1 marks</i>	2	
4	(a) Hukum Kepler Kedua <i>Kepler's Second Law</i>	1	9
(b)	– Luas AFB = Luas CFD <i>Area AFB = Area CFD</i> – Masa sama dari A ke B dan C ke D <i>Same amount of time from A to B and from C to D</i> – Laju A ke B > Laju C ke D <i>Linear speed from A to B > linear speed from C to D</i>	1 1 1	
(c)	$\frac{T_p^2}{r_p^3} = \frac{T_E^2}{r_E^3}$ $r_p = 20r_E$ $\frac{T_p^2}{(20r_E)^3} = \frac{1^2}{r_E^3}$ $T_p = \sqrt{\frac{8000r_E^3 (1)}{r_E^3}}$ $= 89.44 \text{ tahun / years}$	1 1 1	
(d)	– Halaju semakin berkurang. <i>Velocity is decreasing.</i> – Masa yang lebih lama diambil untuk melengkapkan satu sektor orbit mengelilingi Matahari. <i>A longer time is taken to complete one sector of orbit around the Sun.</i>	1 1	
5	(a) Tekanan <i>Pressure</i>	1	
(b)	(i) Haba: Rajah 5.1(b) > Diagram 5.1(a) <i>Heat: Diagram 5.1(b) > Diagram 5.1(a)</i>	1	
(ii)	Suhu gas: Rajah 5.1(b) > Rajah 5.1(a) <i>Temperature of gas: Diagram 5.1(b) > Diagram 5.1(a)</i>	1	

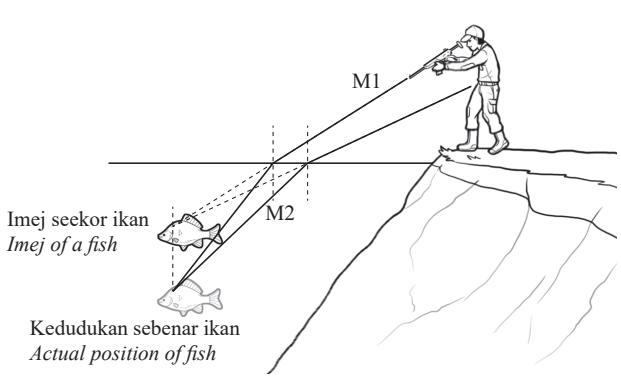
Soalan Questions		Jawapan Answers	Sub markah Subs marks	Markah total Total marks	
	(iii)	Isi padu gas: Rajah 5.1(b) > Rajah 5.1(a) <i>Volume of gas: Diagram 5.1(b) > Diagram 5.1(a)</i>	1		
(c)	(i)	Haba bertambah, suhu bertambah <i>Heat increase, temperature increase</i>	1		
	(ii)	Suhu bertambah, isi padu gas bertambah <i>Temperature increase, volume of gas increase</i>	1		
(d)		Hukum Charles <i>Charles' law</i>	1		
(e)		$\frac{V_1}{T_1} = \frac{V_2}{T_2}$ $\frac{0.035}{35 + 273} = \frac{V_2}{65 + 273}$ $V_2 = 0.038 \text{ m}^3$	1 1		9
6	(a)	Pembiasan <i>Refraction</i>	1		
	(b)	(i)	Sudut pembiasan: Rajah 6.1(a) < 6.1(b) <i>Refraction angle: Diagram 6.1(a) < Diagram 6.1(b)</i>		1
		(ii)	Ketumpatan medium: Rajah 6.1(a) < Rajah 6.1(b) <i>Density of medium: Diagram 6.1(a) < Diagram 6.1(b)</i>		1
		(iii)	Bentuk asal pen: Rajah 6.1(a) = Rajah 6.1(b) <i>Original shape of pen: Diagram 6.1(a) = Diagram 6.1(b)</i>		1
	(c)	(i)	Ketumpatan bertambah, indeks pembiasan bertambah <i>Density of liquid increases, refractive index increases</i>		1
		(ii)	Ketumpatan bertambah, sudut pembiasan bertambah. <i>Density increases, angle of refraction increases.</i>		1
	(d)	(i)	 <p>Imej seekor ikan <i>Imej of a fish</i></p> <p>Kedudukan sebenar ikan <i>Actual position of fish</i></p> <p>Sinar pertama ialah garis lurus dari senapang ke imej ikan. <i>The first ray is a straight line from the gun to the image of the fish.</i></p> <p>Sinar kedua ialah dari lelaki kepada ikan. Sinar dibengkokkan ke arah normal. Lukis kedudukan ikan sebenar di mana ikan berada di bawah gambar. <i>The second ray is from the man to the fish. The ray is bent towards the normal. Draw the actual position of the fish which is below the image.</i></p>		1 1
	(ii)	Dia patut menembak beberapa cm di bawah imej ikan itu. <i>He should shoot a few cm below the image of the fish.</i>	1	9	

Soalan Questions		Jawapan Answers	Sub markah Subs marks	Markah total Total marks
7	(a)	Penghasilan daya gerakan elektrik dalam konduktor apabila ia memotong fluks magnetik <i>The production of an electromotive force in a conductor when it cuts magnetic flux</i>	1	9
	(b)	Diod <i>Diode</i>	1	
	(c)	$V_p I_p = V_s I_s$ $(240)I_p = (12)(0.85)$ $I_p = 0.0425 \text{ A}$	1 1	
	(d) (i)	– Bentuk – 8 <i>8 – shape</i>	1	
		– Medan magnet yang dihasilkan oleh gegelung primer melalui gegelung sekunder sepenuhnya <i>Magnetic field produced by the primary coil passes completely through the secondary coil</i>	1	
	(ii)	– Lebih banyak lapisan nipis <i>More thin layers</i>	1	
		– Mengurangkan arus pusar <i>Reduces eddy currents</i>	1	
(iv)	Transfomer Z <i>Transformer Z</i>	1		
8	(a)	Prinsip Bernoulli <i>Bernoulli's Principle</i>	1	9
	(b)	Daya angkat = Berat kapal terbang <i>Lift force = Weight of aeroplane</i>	1 1	
		Tekanan/ <i>Pressure</i> = $\frac{5.8 \times 10^6}{500}$ $= 1.16 \times 10^4 \text{ Pa}$		
	(c) (i)	– Saiz bola pemicit perlulah besar. <i>Size of the squeeze bulb should be large.</i>	1	
		– Lebih banyak udara boleh ditolak ke dalam tiub tengah. <i>More air can be squeezed through the mid tube.</i>	1	
	(ii)	– Tiub tengah itu mestilah sempit. <i>The mid tube must be narrow.</i>	1	
		– Udara mengalir melalui tiub sempit dengan kelajuan tinggi. Tekanannya rendah. Oleh itu, pewangi ditolak keluar. <i>The air flows through the narrow tube with high speed. The pressure is low. Hence, the perfume can be forced out.</i>	1	
(iii)	– Saiz muncung adalah sempit. <i>Size of the nozzle is narrow.</i>	1		
	– Supaya tekanannya tinggi. Semburan dapat bergerak dengan jauh. <i>So that the pressure is high. The spray can go far.</i>	1		

Soalan Questions		Jawapan Answers	Sub markah Subs marks	Markah total Total marks										
		– Panjang wayar adalah berkadar songsang dengan arus <i>Length of wire is inversely proportional to the current</i> (mana-mana 3 jawapan) (any 3 answers)												
(b)	(i)	$E = V + Ir$ $r = \frac{E - V}{I}$ $= \frac{1.5 - 1.1}{0.2}$ $= 2.0 \Omega$	1 1											
	(ii)	$R_{\text{jumlah} / \text{total}} = \frac{V}{I}$ $= \frac{1.1}{0.2}$ $= 5.5 \Omega$ $\frac{1}{R_{\text{selari} / \text{parallel}}} = \frac{1}{2} + \frac{1}{3}$ $R_{\text{selari} / \text{parallel}} = 1.2 \Omega$ $R_{\text{jumlah} / \text{total}} = R + R_{\text{selari} / \text{parallel}}$ $5.5 = R + 1.2$ $R = 4.3 \Omega$	1 1 1											
(c)		<table border="1"> <thead> <tr> <th>Aspek/Aspect</th> <th>Sebab/Reason</th> </tr> </thead> <tbody> <tr> <td>Bateri disambung secara bersiri <i>Cell connected in series</i></td> <td>Membekal sumber voltan yang lebih tinggi <i>To supply higher voltage</i></td> </tr> <tr> <td>Terminal positif bateri disambung kepada terminal negatif bateri <i>The positive terminal of dry cell is connected to the negative terminal of the cell</i></td> <td>Arus dapat mengalir dalam litar <i>To let current flow in the circuit</i></td> </tr> <tr> <td>Perintang disambung secara bersiri <i>The resistor is connected in series</i></td> <td>Melaraskan beza keupayaan merentasi mentol kepada 2 V supaya mentol-mentol itu bernyala dengan kecerahan normal. <i>To adjust the potential difference across the bulbs to 2 V so that the bulbs can light up with the normal brightness.</i></td> </tr> <tr> <td>Mentol-mentol disambung secara selari <i>Bulbs connected in parallel</i></td> <td>Apabila satu mentol terbakar, mentol-mentol lain masih menyala <i>If one bulb blown out, the other bulbs still light up</i></td> </tr> </tbody> </table>	Aspek/Aspect	Sebab/Reason	Bateri disambung secara bersiri <i>Cell connected in series</i>	Membekal sumber voltan yang lebih tinggi <i>To supply higher voltage</i>	Terminal positif bateri disambung kepada terminal negatif bateri <i>The positive terminal of dry cell is connected to the negative terminal of the cell</i>	Arus dapat mengalir dalam litar <i>To let current flow in the circuit</i>	Perintang disambung secara bersiri <i>The resistor is connected in series</i>	Melaraskan beza keupayaan merentasi mentol kepada 2 V supaya mentol-mentol itu bernyala dengan kecerahan normal. <i>To adjust the potential difference across the bulbs to 2 V so that the bulbs can light up with the normal brightness.</i>	Mentol-mentol disambung secara selari <i>Bulbs connected in parallel</i>	Apabila satu mentol terbakar, mentol-mentol lain masih menyala <i>If one bulb blown out, the other bulbs still light up</i>	2 2 2 2	
Aspek/Aspect	Sebab/Reason													
Bateri disambung secara bersiri <i>Cell connected in series</i>	Membekal sumber voltan yang lebih tinggi <i>To supply higher voltage</i>													
Terminal positif bateri disambung kepada terminal negatif bateri <i>The positive terminal of dry cell is connected to the negative terminal of the cell</i>	Arus dapat mengalir dalam litar <i>To let current flow in the circuit</i>													
Perintang disambung secara bersiri <i>The resistor is connected in series</i>	Melaraskan beza keupayaan merentasi mentol kepada 2 V supaya mentol-mentol itu bernyala dengan kecerahan normal. <i>To adjust the potential difference across the bulbs to 2 V so that the bulbs can light up with the normal brightness.</i>													
Mentol-mentol disambung secara selari <i>Bulbs connected in parallel</i>	Apabila satu mentol terbakar, mentol-mentol lain masih menyala <i>If one bulb blown out, the other bulbs still light up</i>													

Soalan Questions		Jawapan Answers	Sub markah Subs marks	Markah total Total marks
		<p>Litar X Circuit X</p>	<p>Bateri disambung secara bersiri, terminal positif bateri disambung kepada terminal negatif bateri, perintang disambung secara bersiri, mentol-mentol disambung secara selari Cell connected in series, the positive terminal of dry cell is connected to the negative terminal of the cell, the resistor is connected in series, bulbs connected in parallel</p>	<p>2</p> <p>20</p>

Bahagian C / Section C

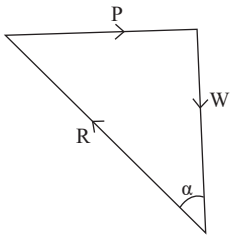
Soalan Questions		Jawapan Answers	Sub markah Subs marks	Markah total Total marks
11	(a)	<p>Daya tunggal yang mewakili jumlah secara vektor dua atau lebih daya yang bertindak ke atas sesuatu objek. Single force represents the sum of two or more forces in vector acted on an object.</p>	1	
	(b)	<p>F_x dalam Rajah 11.1(a) < Rajah 11.1(b) F_x in Diagram 11.1(a) < Diagram 11.1(b)</p>	1	
		<p>W_x dalam Rajah 11.1(a) < Rajah 11.1(b) W_x in Diagram 11.1(a) < Diagram 11.1(b)</p>	1	
<p>Sudut θ dalam Rajah 11.1(a) < Rajah 11.1(b) Angle θ in Diagram 11.1(a) < Diagram 11.1(b)</p>		1		
<p>Semakin bertambah sudut, θ, semakin bertambah F_x Angle, θ increase, F_x increase</p>		1		
<p>Semakin bertambah sudut, θ, semakin bertambah pecutan Angle, θ increase, acceleration increase.</p>		1		
(c)	 <p>Lukis dan label garis W yang betul Draw and label correct line for W</p> <p>Lukis dan label garis R yang betul Draw and label correct line for R</p> <p>Tandakan arah W dan R yang betul Mark the correct direction of W and R</p> <p>Kedudukan α dan bentuk segi tiga yang betul Correct position of α and shape of triangle</p>	<p>1</p> <p>1</p> <p>1</p> <p>1</p>		

Soalan Questions		Jawapan Answers		Sub markah Subs marks	Markah total Total marks
(d)		Aspek/Aspect	Sebab/Reason		
		Menolak mesin rumput <i>Pushing the lawn mover</i>	Daya yang besar dikenakan ke atas rumput <i>Greater force is applied on the grass</i>	2	
		Jisim besar <i>Large mass</i>	Lebih stabil <i>More stable</i>	2	
		Bilah pemotong yang besar <i>Bigger cutter blade</i>	Lebih banyak rumput boleh dipotong <i>More grass can be cut</i>	2	
		Sudut yang luas <i>Larger angle</i>	Untuk menghasilkan daya bertindak ke bawah yang besar <i>To produce large force acting downward</i>	2	
		Tangki bahan api besar <i>Large fuel tank</i>	Memotong rumput lebih lama. <i>Cutting grass for longer time.</i>	2	20